



**ISO 10243
NAMMS
JIS B 5012**

Die Spring Catalogue World-wide Solutions



Barnes Group

United Kingdom

Associated Spring SPEC
European Headquarters
Unit 4, Grosvenor Business Centre
Vale Park, Evesham
Worcs. WR11 1GS
Tel: (44) 1386 443366
Fax: (44) 1386 446669
E-mail: sales@assocspring.co.uk
www.assocspring.co.uk

Brazil

www.asbg.com
Associated Spring Raymond
Rua Wallace Barnes 301A
Distrito Industrial
Caixa Postal 1288
Campinas, SP Brazil
CEP 13054-701
Tel: (55) 193 725 1083
Fax: (55) 193 725 1084
E-mail: brazil@asraymond.com
www.asbg.com

Canada

Associated Spring Raymond
3100 Mainway
Burlington, Ont. L7M 1A3
Tel: 800 263 4256
Fax: 814 664 0312
www.asbg.com

Czech Republic

Cecho – Bohumil Cempírek S.R.O.
Polnicka 151
591 01 Zdár nad Sázavou
Tel: 00 420 566 620705
Fax: 00 420 566 620706
E-mail: pruziny@cecho.cz
www.cecho.cz

Denmark

Sodemann Industrifjedre A/S
Industrivej 21
DK 8260 Viby-J
Denmark
Tel: (45) 86 72 00 99
Fax: (45)86 29 97 86
E-mail: sif@fjedre.dk
www.fjedre.dk

Finland and Russia

Meconet Oy
Honkanummentie 8
FI-01260 Vantaa
Tel: +358 (0) 207 699 300
Fax: +358 (0) 207 699 335
E-mail: reino.heikkinen@meconet.net
www.meconet.net

France

Ressorts SPEC
Bâtiment HERMES 2
ZA de Pissaloup
4 rue Edouard Branly
78190 TRAPPES
Tel: (33) 01 30 68 6363
Fax: (33) 01 30 68 4050
E-mail: info@ressortsspec.com
www.ressortsspec.com

Germany

Febrotec GmbH
Frankfurter Strasse 76
D-58553 Halver
Tel: (49) 2353 4866
Fax: (49) 2353 4301
E-mail: federn@febrotec.de
www.febrotec.de

Hungary

Biotek KFT
1165 Budapest
Bokenyfoldi UT 104
Hungary
Tel: (36) 1 434 2900
Fax: (36) 1 260 8635
E-mail: biotek@biotek.hu

India

Star Circlips & Engineering Ltd
Hingna Industrial Estate
Nagpur-440 016
Tel : (91) 7104 234742
Fax : (91) 7104 237628
E-mail: sales@starcirclips.net
www.starcirclips.com

Israel

Delta Elkon Mechanical Products Ltd.
P.O. Box 8262
New Industrial Zone
South Netaneya 42504
Tel: (972) 1 599 500 557
Fax: (972) 9 865 8492
E-mail: natasha@delta-elkon.co.il
www.delta-elkon.co.il

Italy

Metersprings Srl
Via S. FILIPPO,1
13900 Biella (BI)
Tel: (39) 015 23581
Fax: (39) 015 23646
E-mail: meter@meterspec.it
www.meterspec.it

Mexico

Raymond Distribution - Mexico SA de CV
Av. Concordia No 4601-A
Col. Apodaca Centiro
Apodaca,
N.L. Mexico
C.P. 66600
Tel: 52 (81) 81 45 0680
Fax: 52 (81) 81 45 0679
E-mail: ventas@asraymond.com
www.asraymond.com

The Netherlands

Amatec
Jac P Thijsseweg 14
NL-2408 ER
Alphen Aan Den Rijn
The Netherlands
Tel: (31) 172 439359
Fax: (31) 172 440313
E-mail: info@amatec.nl
www.amatec.nl

Poland

FCPK-BYTÓW Sp. z.o.o.
ul.Le. borska 26
77-100 Bytów
Tel: (48) 59 822 2026
Fax: (48) 59 822 9703
E-mail: fcpc@fcpc.com.pl
www.fcpc.com.pl

Singapore

Associated Spring Raymond Asia Pte Ltd.
15A Tuas Road
Jurong
Singapore 638517
Tel: (65) 6863 5636
Fax: (65) 6863 6325
E-mail: sales@raymondasia.com
www.raymondasia.com

Spain

Barnes Group Spain, S.R.L.
La Peña 6 - Pab. 5
01013 Vitoria-Gasteiz
Tel: (34) 945 147542
Fax: (34) 945 137655
E-mail: ventas@bgespana.com
www.bgespana.com

Sweden

EWES STÅLFJÄDER AB
Lundavagen 45
S-330 10 Bredaryd
Tel: (46) 370 86700
Fax: (46) 370 86249
E-mail: info@ewes.se
www.ewes.se

Switzerland

Ressorts du Léman
Chemin de la Gravière 16
1225 Chêne-Bourg
Tel: +41 (0) 22 860 13 10
Fax: +41 (0) 22 860 13 12
Email: info@ressortsduleman.ch
www.ressortsduleman.ch

USA

Associated Spring Raymond
370 W. Dussel Drive
Suite A
Maumee, OH 43537-1604
Tel: (1) 419 891 9292
Fax: (1) 419 891 9192
www.asraymond.com

Whilst all reasonable efforts are made to ensure the correctness of the information provided, we cannot be held responsible for any inaccuracies in, or omissions from, this brochure.

Re-Order Code MBL20239-1

©. World copyright 2012 Barnes Group Inc.

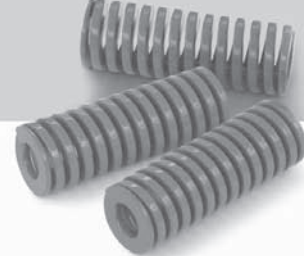

DIE SPRINGS

Associated Spring Raymond Die Springs are manufactured using a wire cross section developed to provide optimum balance between load carrying characteristics and cycle life.

Produced under carefully controlled processes with special equipment developed by Barnes Group Inc's research and development facilities.

All of the manufacturing steps are closely monitored by rigid quality controls, inspection and testing to ensure that the long service life engineered into every die spring is constant.

Full technical specifications available on request from Associated Spring.

ISO 10243 | NAMMS | JIS B 5012



RESSORTS DE COMPRESSION EXTRA-RAIDES

Les ressorts extra raides de RESSORTS SPEC sont fabriqués à partir d'un fil à section trapézoïdale, afin de garantir un niveau de contrainte minimum pendant le travail du ressort et une longévité maximale.

Ils sont faits sur des équipements spéciaux, sous contrôle rigoureux par l'équipe de Recherche du Groupe BARNES, bénéficiant d'une longue expérience.

Toutes les étapes de fabrication sont effectuées sous un contrôle qualité strict (inspection, mesures, tests, . . .) afin d'assurer une longévité et des performances optimales.

Détails techniques fournis sur simple demande.

ISO 10243 | NAMMS | JIS B 5012



MUELLES/RESORTES DE TROQUEL

Los muelles de troquel de Barnes Group Raymond se fabrican a partir de un hilo metálico de sección transversal desarrollado para garantizar un equilibrio óptimo entre la capacidad de carga y su duración máxima.

Nuestro proceso de producción se realiza mediante cuidadosos controles y con un equipo especial desarrollado por el equipo de investigación del Grupo Barnes.

Todas las etapas de la fabricación se efectúan bajo un estricto control de calidad, inspección y exámenes del producto para así garantizar una larga vida útil de cada uno de los muelles de troquel.

Detalles técnicos facilitados sobre demanda.

ISO 10243 | NAMMS | JIS B 5012



WERKZEUGFEDERN

Die Werkzeugfedern von Associated Spring Raymond werden mit einem Drahtquerschnitt hergestellt, der ein optimales Gleichgewicht zwischen Tragfähigkeit und Lebensdauer gewährleistet.

Die Federn werden in sorgfältig kontrollierten Prozessen unter Verwendung von Spezialausrüstung hergestellt, die von der Forschungs- und Entwicklungseinrichtung der Barnes Group entwickelt wurde.

Alle Fertigungsschritte werden streng überwacht und unterliegen rigorosen Qualitätskontrollen, Prüfungen und Testverfahren, um sicherzustellen, dass für jede Feder eine lange Nutzungsdauer garantiert werden kann.

Vollständige technische Spezifikationen sind auf Anfrage von Associated Spring erhältlich.

ISO 10243 | NAMMS | JIS B 5012



MOLLE PER STAMPI

Le molle per stampi sono costruite utilizzando un filo di sezione speciale per ottenere un ottimo rapporto fra i carichi di lavoro e la durata.

Le molle sono prodotte con attrezzature speciali e con processi accuratamente controllati dai laboratori di ricerca e sviluppo del Gruppo Barnes.

Tutte le fasi di produzione sono monitorate da rigidi controlli di qualità, ispezioni e test, al fine di garantire l'uniformità della durata delle molle nel tempo.

Ulteriori dettagli tecnici sono disponibili su richiesta.

ISO 10243 | NAMMS | JIS B 5012



MOLAS DE MATRIZ

As Molas de Matriz da Associated Spring Raymond são fabricadas com usando arame de seção transversal projetada para proporcionar um equilíbrio ideal entre as características de condução de carga e vida útil.

São produzidas sob processos cuidadosamente controlados, com equipamentos especiais elaborados pelo departamento de pesquisa e desenvolvimento do Barnes Group, Inc.

Todas as etapas de fabricação acompanhadas de perto por rígidos controles de qualidade, inspeções e testes para garantir que a vida útil seja um fator importante e constante na fabricação de cada mola de matriz.

Especificações técnicas completas estão disponíveis, podendo ser solicitadas a Associated Spring.

ISO 10243 | NAMMS | JIS B 5012



DIE SPRING FEATURES & BENEFITS

Superior Materials & Wire Profile

Features

- All Raymond die springs are made from high tensile strength chromium alloy steels.
- Optimal wire cross section.
- Spring ends are ground square.
- Other raw materials are available for special conditions and environments.

Benefits

- Inherent toughness to withstand heavy load demands.
- Superior performance in high stress applications.
- Heat resistance up to 230°C.
- Readily available, cost efficient raw material.
- Consistent controlled metallurgy.
- Offers maximum design possibilities.
- Wire cross section provides optimum deflection and protection against failure due to excessive

stress build-up.

- Square ends create reliable, flat, maximum load-bearing surface.
- Specialty materials available to meet customer requirements.

Dimensional Consistency

Features

- Dimensional requirements remain consistent and measurably the same from one batch of springs to the next.

Benefits

- Provides uniform spring performance.
- Ensures consistent rate recordings.
- Greater load accuracy at a given test height.
- Certainty that OD will work freely in prescribed hole and ID will work freely over prescribed rod.
- Raymond assurance of the highest production and quality standards.
- Reliable performance engineered into every Raymond die spring.

Longer Spring Life

Features

- Engineered to better withstand shock loading.
- Designed to endure constant high-speed deflections.
- Shot-peened to increase fatigue life.
- Less downtime.

Benefits

- Reliable, trouble-free performance.
- Increased fatigue life by as much as 30%.
- Reduced spring breakage.
- Uniform performance over a longer lifetime.
- More cost effective.
- Extra performance margins.

Excellent Deflection

Features

- Springs provide greater available travel to solid.
- More travel in each spring.

Benefits

- Higher load capacities.
- Increased fatigue life.
- Greater application flexibility.
- More reliable performance.
- Lower solid height.



CARACTÉRISTIQUES ET AVANTAGES

Matériaux Supérieurs et type de fil

Caractéristiques

- Tous nos ressorts sont fabriqués à partir d'alliages au chrome à haute résistance aux tensions.
- Fil trapézoïdal.
- Extrémités rapprochées, meulées.
- Autres matériaux disponibles pour des conditions et des environnements particuliers.

Avantages

- Dureté permettant de supporter des charges importantes.
- Performances supérieures dans des applications de forte compression.
- Résistance à 230°C.
- Matériau facilement disponible, coût moindre.
- Contrôles métallurgiques constants.
- Possibilité de conceptions optimales.
- Fil trapézoïdal permettant une déflexion maximale et une protection contre tout risque de dommage causé par la sollicitation excessive du ressort.
- Les extrémités rapprochées et meulées offrent une surface d'appui optimale.
- Matériaux spéciaux disponibles pour satisfaire les exigences du client.

Consistance Dimensionnelle

Caractéristiques

- Les exigences dimensionnelles restent constantes d'une fabrication à l'autre.

Avantages

- Fournit une performance du ressort uniforme.
- Assure des rapports de raideur constante.
- Plus grande précision de charge à une hauteur donnée.
- Assurance que le ressort travaillera dans des conditions optimales par rapport au logement et à l'axe conseillés.
- Assurance des meilleurs standards de production et de qualité.
- Performances mécaniques fiables.

Vie du Ressort

Caractéristiques

- Fabriqués pour mieux supporter les chocs.
- Conçus pour endurer des accoups.
- Grenillés pour augmenter la durée de vie.
- Moins d'arrêt de machines.

Avantages

- Performances fiables.
- Augmentation de durée de vie de 30%.
- Diminution des risques de ruptures.
- Performances constantes pour une longue durée de vie.
- Meilleure rentabilité.
- Marges extra performantes.

Déflexion Excellente

Caractéristiques

- Les ressorts offrent une plus grande facilité pour atteindre la hauteur solide.
- Course plus performante pour chaque ressort.

Avantages

- Capacités à supporter des charges plus importantes.
- Durée de vie augmentée.
- Grande flexibilité d'applications.
- Performances plus fiables.
- Hauteur solide réduite.



VENTAJAS Y CARACTERÍSTICAS DE LOS MUELLES DE TROQUEL

Materiales de calidad superior y tipo de hilo

Características

- Todos los muelles de troquel Raymond están fabricados a partir de aceros al cromo aleados de alta ductilidad.
- Hilo metálico de sección transversal óptimo.
- Los extremos del muelle se rectifican para dar una sección cuadrada.
- Disponibles otros materiales para condiciones y ambientes especiales.

Beneficios

- Dureza que permite soportar cargas pesadas.
- Resistencia térmica hasta 230° C.
- Gran disponibilidad, bajo coste.
- Controles metalúrgicos constantes.
- Grandes posibilidades de diseño.
- El hilo metálico de sección transversal ofrece una óptima deflexión y protección contra los posibles fallos debidos a una carga excesiva del muelle.
- Los extremos de sección transversal cuadrada ofrecen una superficie de apoyo óptima.
- Disponibles materiales especiales para satisfacer las exigencias del cliente.

Consistencia Dimensional

Características

- Las exigencias dimensionales se mantienen constantes de una fabricación a otra.

Ventajas

- Proporciona el funcionamiento uniforme del muelle.
- Garantiza un registro de evaluación constante.
- Gran precisión de carga a una altura predeterminada.
- Certeza de que el muelle trabajará de forma óptima atendiendo al orificio y a la varilla predeterminados.
- Garantía Raymond de cumplimiento de las normativas de producción y de calidad.
- Funcionamiento óptimo garantizado para cada muelle Raymond.

Vida útil más larga

Características

- Diseñados para soportar mejor los impactos de la carga.
- Concebidos para resistir las continuas deflexiones.
- Granallado para prolongar la vida útil del muelle.
- Menor periodo de paralización del trabajo.

Ventajas

- Funcionamiento fiable y sin problemas.
- 30% de aumento de la vida útil.
- Disminución de roturas.
- Rendimiento constante durante una vida útil mayor.
- Mayor rentabilidad.
- Márgenes extra de rendimiento.

Deflexión excelente

Características

- Los muelles proporcionan una mayor carrera para alcanzar la altura sólida.
- Mayor carrera en cada muelle.

Ventajas

- Capacidad para cargas mayores.
- Aumento de la vida útil.
- Gran flexibilidad en las aplicaciones.
- Funcionamiento fiable.
- Menor altura sólida.





SYSTEM-DRUCKFEDERN EIGENSCHAFTEN & VORTEILE

Herausragendes Material & Drahtprofil Eigenschaften

- Alle Raymond System-Druckfedern werden aus legiertem Chromstahl mit hoher Zugfestigkeit hergestellt.
- Optimaler Drahtquerschnitt.
- Enden sind quadratisch geschliffen.
- Andere Rohmaterialien sind verfügbar für spezielle Anwendungen und Einsatzbereiche.

Vorteile

- Eigene Widerstandsfähigkeit, um den Anforderungen schwerer Belastungen zu widerstehen.
- Herausragende Leistung bei Anwendungen mit hohen Belastungen.
- Hitzebeständig bis zu 230° C.
- Leicht verfügbares, günstiges Rohmaterial.
- Gleichmäßig kontrollierte Metallurgie.
- Bietet beste Designmöglichkeiten.
- Drahtquerschnitt bietet optimale Durchfederung und Schutz vor Versagen auf Grund einer übermäßigen Stressanstauung.
- Quadratische Enden bieten zuverlässige, flache, maximal belastbare Oberflächen.
- Spezialmaterialien verfügbar um Kundenanforderungen zu entsprechen.

Dimensionale Beschaffenheit

Eigenschaften

- Dimensionale Anforderungen bleiben konsistent und meßbar gleich, von einem Satz Federn bis zum Nächsten.

Vorteile

- Bietet einheitliche Federleistungen.
- Gewährleistet gleichmäßige Ratenaufzeichnungen.
- Größere Lastpräzision bei vorgegebener Testhöhe.
- Gewissheit, dass Außendurchmesser frei im vorgegebenen Loch funktioniert und Innendurchmesser frei über vorgegebener Stange funktioniert.
- Raymond Garantie der höchsten Produktions- und Qualitätsstandards.
- Zuverlässige Leistung konstruiert in jeder Raymond System-Druckfeder.

Längere Lebensdauer der Feder

Eigenschaften

- Konstruiert, um der Schockbelastung besser zu widerstehen.
- Konzipiert, um konstante

Hochgeschwindigkeitsdurchfederungen auszuhalten.

- Kugelgestrahl um die Lebensdauer zu steigern.
- Weniger Stillstandszeiten.

Vorteile

- Zuverlässige, störfreie Leistung.
- Gesteigerte Lebensdauer um so viel wie 30 %.
- Weniger Federbrüche.
- Einheitliche Leistung über einen längeren Zeitraum.
- Günstiger.
- Weitere Leistungsgewinnspannen.

Ausgezeichnete Durchfederung

Eigenschaften

- Federn bieten größere Federung bis solide.
- Mehr Federung in jeder Feder.

Vorteile

- Höhere Lastkapazitäten.
- Gesteigerte Lebensdauer.
- Größere Anwendungsvielfalt.
- Zuverlässigere Leistung.
- Niedrige solide Höhe.



MOLLE PER STAMPI: CARATTERISTICHE E VANTAGGI

Materiali di qualità e sezione del filo

Caratteristiche

- Tutte le molle per stampi Raymond sono realizzate in leghe di acciaio al cromo di elevata resistenza alla trazione.
- Sezione trasversale del filo ottimale.
- Le estremità delle molle sono quadrate.
- Sono disponibili altri materiali grezzi per condizioni e ambienti particolari.

Vantaggi

- Robustezza inerente per resistere a esigenze di carichi pesanti.
- Prestazioni eccellenti nell'ambito di applicazioni ad alte sollecitazioni.
- Resistenza al calore fino a 230 °C.
- Materiale grezzo disponibile con facilità e a costi economici.
- Metallurgia controllata costante.
- Offre possibilità massime di design.
- La sezione trasversale del filo fornisce una deflessione ottimale e protezione contro guasti dovuti a un accumulo eccessivo di sollecitazioni.
- Le estremità quadrate creano una superficie piatta e affidabile per una portata massima.
- Sono disponibili materiali speciali per soddisfare le esigenze dei clienti.

Consistenza dimensionale

Caratteristiche

- I requisiti dimensionali rimangono consistenti e ogni lotto di molle è uguale a quello successivo in maniera comprovabile.

Vantaggi

- Le molle presentano prestazioni uniformi.
- Si garantiscono registrazioni consistenti dei valori di rigidità.
- Maggiore precisione del carico a una determinata altezza di prova.
- Certezza che il diametro esterno si può muovere liberamente nel foro prescritto e che il diametro interno si può muovere liberamente lungo l'albero prescritto.
- Garanzia di Raymond dei più elevati standard di produzione e qualità.
- Prestazioni affidabili intrinseche di ogni molla per stampi Raymond.

Maggiore durata delle molle

Caratteristiche

- Progettate per resistere meglio al carico d'urto.
- Ideate per sopportare deflessioni costanti ad alta velocità.
- Pallinatura per aumentare la resistenza a fatica.
- Meno periodi di inattività.

Vantaggi

- Prestazioni affidabili per lavorare senza preoccupazioni.
- Resistenza a fatica aumentata fino al 30%.
- Rottura delle molle meno frequente.
- Prestazioni costanti per un periodo più lungo.
- Costi più vantaggiosi.
- Margini prestazionali addizionali.

Deflessione eccellente

Caratteristiche

- Le molle hanno una maggiore corsa a blocco.
- Ogni molla presenta una corsa maggiore.

Vantaggi

- Maggiori capacità di carico.
- Maggiore resistenza a fatica.
- Maggiore flessibilità di applicazione.
- Prestazioni più affidabili.
- Minore altezza a blocco.



CARACTERISTICAS E BENEFICIOS DAS MOLAS DE MATRIZ

Materiais Superiores e Perfil do Arame

Características

- Todas as molas de matriz da Raymond são construídas de ligas de aço de cromo de alta resistência à tração.
- Seção transversal do arame otimizada.
- Extremidades da mola possuem usinagem quadrada.
- Outras materiais-primas estão disponíveis para ambientes e condições especiais.

Benefícios

- Resistência inerente para suportar as exigências de cargas pesada.
- Desempenho superior em aplicações de alta tensão.
- Resistência térmica de até 230 ° C.
- Matéria-prima com eficiência de custo e prontamente disponível.
- Metalurgia consistentemente controlada.
- Oferece possibilidades máximas de projetos.
- Seção transversal do arame fornece deflexão ideal e proteção contra falha devido ao acúmulo excessivo de tensão.
- Extremidades quadradas criam superfície de suporte de carga plana e confiável.
- Materiais especializados disponíveis para atender as necessidades dos clientes

Consistência dimensional

Características

- Exigências dimensionais permanecem consistentes e mensuravelmente as mesmas de um lote de molas para o outro.

Benefícios

- Proporciona um desempenho uniforme da mola.
- Garante registros de coeficiente constantes.
- Maior precisão de carga a uma altura de teste específico.
- Certeza de que OD funcionara livremente no furo prescrito e que ID funcionará livremente sobre haste prescrita.
- Garantia da Raymond dos mais altos padrões de qualidade e produção.
- Desempenho confiável projetado em cada mola de matriz da Raymond.

Maior vida útil da Mola

Características

- Projetadas para suportar melhor a carga de choque.
- Projetadas para resistir constantes deflexões com velocidade elevada.
- Tamboreamento para maior resistência.
- Tempo inoperante reduzido.

Benefícios

- Confiáveis e desempenho sem problemas.
- Aumento da resistência da vida útil à fadiga em até 30%.
- Redução em quebra da mola.
- Desempenho uniforme durante um maior tempo de vida.
- Custo mais eficaz.
- Margens de desempenho adicionais.

Deflexão Excelente

Características

- As molas proporcionam um maior percurso disponível ao sólido (totalmente comprimida).
- Mais percurso em cada mola.

Benefícios

- Com capacidade para cargas elevadas.
- Aumento da resistência da vida útil à fadiga.
- Uma maior flexibilidade de aplicação.
- Um desempenho mais confiável.
- Uma altura sólida menor.





PROPER DIE SPRING APPLICATION

DO make spring selection a part of the early design function, and work within the spring's physical limits. It's best to determine which springs and how many are needed for the job before the die is built.

DO preload each spring into the assembled tool to prevent the possibility of shock loading, which causes a stress surge in the vibration frequency and may result in early spring failure.

Do provide safeguards from adverse external elements such as heat, corrosive atmosphere, metal chips and other obstructions

DO provide proper guidance on all springs to reduce the chance of buckling. As a general rule, if the free length is more than four times the mean diameter of the spring, it could have a buckling problem under compression. This is solved by using a guide rod, boring a pocket, or both.

DO deepen spring pockets proportionately when the die is sharpened to maintain the same spring travel and load level. Each spring pocket needs to have a flat bottom and square corners, so the spring will provide uniform stress on each coil as it is compressed.

DO perform preventative maintenance on a regularly scheduled basis. Keep records on the number of cycles each die performs, and replace all the die springs at predetermined intervals.

DON'T replace only one spring, or mix springs of assorted lengths and deflection ranges on a die. Instead of using an unbalanced, mixed assembly of old and new springs, replace all of the springs to distribute the load evenly.

DON'T alter a die spring by cutting off coils or grinding the inside or outside diameter. Altering a die spring causes early failure and creates the potential for damaging the die.

DON'T expect maximum performance life from a spring that is producing at maximum load. Although die springs are designed to produce maximum load, they are highly stressed when maximum loads are met.

DON'T wait – make spring selection a part of the early design function, and work within the spring's physical limits. It's best to determine which springs and how many are needed for the job before the die is built.

DO call – our knowledgeable customer service and engineering professionals are always available to assist you with everything from custom sizes and special materials to technical questions and unusual applications.



UTILISATION CORRECTE DU RESSORT

Assurez-vous que la sélection du ressort le plus adapté soit une priorité. Il est préférable de déterminer un ressort avant le façonnage du moule.

Pré contraignez chaque ressort dans l'outil d'assemblage afin d'éviter tout choc dû à la charge et à la pression, ce qui pourrait entraîner des dommages sur le ressort.

Assurez-vous qu'aucun élément extérieur ne vienne perturber le bon fonctionnement, tel que la chaleur, une atmosphère corrosive, . . .

Assurez-vous que le ressort soit bien guidé afin de réduire les risques de déformation. En règle générale, si la longueur libre est 4 fois supérieure au diamètre moyen du ressort, un risque de déformation est à craindre. Ceci peut être évité en guidant le ressort par un axe et un logement.

Assurez-vous que la base du logement soit bien plate, et que ses coins soient carrés afin que la charge et la compression soient appliquées uniformément.

Effectuez des contrôles fréquents et de façon régulière. Notez le nombre de cycles réalisé par chaque ressort et remplacez les à des intervalles prédéterminés.

Ne remplacez pas uniquement un ressort et ne mélangez pas des ressorts de différentes longueurs. Au lieu d'utiliser un mélange de ressorts neufs et usagés, remplacez tous les ressorts pour obtenir une distribution de la charge égale.

Ne modifiez pas un ressort en coupant ses extrémités ou en meulant les diamètres intérieurs et extérieurs. Altérer un ressort diminue la durée de vie et peut entraîner des défauts au niveau du fonctionnement de la matrice.

Ne vous attendez pas à obtenir des performances maximum de durée vie avec un ressort utilisé à sa charge maximum. Bien que les ressorts d'outil de presse soient prévus pour fournir des charges maximum, le taux de fatigue est très élevé lorsque les charges maximum sont atteintes.

N'attendez pas. Le choix d'un ressort doit être une priorité pour le bon fonctionnement des moules. Il est préférable de déterminer un ressort avant le façonnage de la matrice.

Appelez. Notre équipe de professionnels est à votre disposition pour vous assister dans le choix des ressorts et pour répondre à toutes vos attentes.



UTILIZACIÓN CORRECTA DEL MUELLE DE TROQUEL

Escoja el muelle al tiempo que diseña la función y trabaje teniendo en cuenta los límites físicos del muelle. Es mejor determinar qué muelles y cuántos son necesarios para la aplicación antes de construir el troquel.

Cargue por adelantado cada muelle en la herramienta ya montada para prevenir la posibilidad de un impacto de la carga, lo que causa una variación muy rápida de la tensión en la frecuencia de vibración y puede derivar en un fallo prematuro del muelle.

Asegúrese de protegerlo de cualquier elemento externo, tales como calor, atmósfera corrosiva, astillas de metal y otras obstrucciones.

Proporcione una buena guía a todos los muelles para reducir el riesgo de deformación. Como norma general, si la longitud libre es más de cuatro veces mayor que el diámetro medio del muelle, podría tener un problema de deformación bajo compresión. Esto se soluciona utilizando una varilla guía, una cavidad o ambas a la vez.

Asegúrese de que las cavidades tengan una profundidad proporcionada cuando el troquel esté afilado para mantener la misma carrera y nivel de carga del muelle. Cada una de las cavidades ha de tener el fondo plano y las esquinas cuadradas, de tal forma que se efectúe una tensión uniforme en cada una de las espiras cuando se comprima.

Efectúe frecuentes controles y de manera regular. Anote el número de ciclos que realice cada muelle y sustituya los muelles a intervalos determinados. No sustituya sólo un muelle ni mezcle muelles de distinta longitud y deflexión. En vez de utilizar una mezcla desequilibrada de muelles nuevos y usados, sustituya todos de manera que la carga se distribuya de forma uniforme.

No modifique ningún muelle de troquel cortando espiras o puliendo el diámetro interior o exterior. La modificación de un muelle de troquel causa el fallo prematuro del muelle y puede traer consigo un gran daño al troquel.

No espere que la esperanza de vida de un muelle vaya a ser la máxima si se aplica la carga máxima. A pesar de que están concebidos para producir cargas máximas, se tensan mucho cuando se alcanzan las cargas máximas.

No espere y seleccione el muelle durante la operación de diseño y trabaje teniendo en cuenta sus limitaciones físicas. Lo mejor es determinar qué muelles y cuántos son necesarios antes de construir el troquel.

Llame a nuestro servicio de atención al cliente y nuestros profesionales están a su disposición para ayudarle en la elección de su muelle de troquel y para responder a sus consultas.





DIE RICHTIGE ANWENDUNG EINER SYSTEM-DRUCKFEDER

Treffen Sie eine Federauswahl im Rahmen der ersten Designfunktion und arbeiten Sie innerhalb der physikalischen Grenzen der Feder. Am besten vor dem Bau der Federform festlegen, welche Federn und wie viele für die Anwendung benötigt werden.

Laden Sie jede Feder in das montierte Werkzeug ein, um die Möglichkeit einer Schockbelastung zu vermeiden, welche eine Stresswelle in der Vibrationsfrequenz verursacht und zu einem vorzeitigen Federversagen führen kann.

Bieten Sie Schutzmaßnahmen vor nachteiligen, externen Einwirkungen, wie z. B. Hitze, korrosive Atmosphäre, Metallteilchen und andere Hindernisse.

Bieten Sie die richtige Ratgebung bei allen Federn, um die Möglichkeit eines eventuellen Knickens zu verringern. Als Allgemeinregel gilt, wenn die freie Länge mehr als das Vierfache des mittleren Durchmessers der Feder beträgt, könnte es bei einer Komprimierung zu einem Knickproblem führen. Dies kann durch Anwendung einer Leitstange, dem Ausdrehen einer Tasche oder beidem behoben werden.

Vertiefen Sie die Federtaschen proportional beim Schärfen der Federform geschärft wird um die gleiche Federung und den Belastungsgrad beizubehalten. Jede Federtasche muss eine flache Unterseite und quadratische Ecken besitzen, damit die Feder einheitliche Belastung auf jeder Feder während des Komprimierens bietet.

Führen Sie eine präventive Wartung zu regelmäßig festgelegten Zeiten durch. Führen Sie Buch über die Anzahl aller Durchläufe, in der jede Federform vorgeformt wird und ersetzen Sie alle System-Druckfedern zu regelmäßig festgelegten Zeitpunkten.

Ersetzen Sie nicht nur eine Feder oder eine Mischung aus Federn unterschiedlicher Länge und Durchfederungsgraden in einer Form. Statt eine unbalancierte Mischung aus alten und neuen Federn zu benutzen sollten Sie alle Federn ersetzen, um die Ladung gleichmäßig zu verteilen.

Ändern Sie nicht die System-Druckfeder, indem Sie Federn kürzer schneiden oder die Innenseite oder den Außendurchmesser abschleifen. Die Änderung einer System-Druckfeder kann ein vorzeitiges Versagen herbeiführen und erzeugt das Potential zur Beschädigung der Form.

Erwarten Sie keine maximale Leistung von einer Feder, die unter maximaler Last steht. Obwohl System-Druckfedern konzipiert wurden um maximale Lasten zu produzieren, stehen Sie sehr unter Druck, wenn den maximalen Lasten entsprochen wird.

Warten Sie nicht, machen Sie die Federwahl zu einer ersten Designfunktion und arbeiten Sie innerhalb der physikalischen Grenzen der Feder. Am besten vor dem Bau der Federform festlegen, welche Federn und wie viele für die Anwendung benötigt werden.

Rufen Sie uns an: unser fachmännischer Kundendienst und unsere qualifizierten Techniker stehen immer bereit, um Ihnen behilflich zu sein: von Spezialmaßen und Spezialmaterialien bis hin zu technischen Fragen und außergewöhnlichen Anwendungen.



APPLICAZIONE CORRETTA DELLA MOLLE PER STAMPI

Sì: incorporate la selezione della molla nella fase iniziale della progettazione e rispettate i limiti fisici. Conviene determinare quali e quante molle sono necessarie prima della costruzione dello stampo.

Sì: caricate ogni molla all'interno dello strumento assemblato per evitare il verificarsi di un carico d'urto, che causa un aumento delle sollecitazioni nella frequenza delle vibrazioni e può risultare in un guasto precoce della molla.

Sì: fornite protezioni contro gli elementi esterni avversi quasi calore, atmosfera corrosiva, schegge di metallo e altre ostruzioni.

Sì: fornite una guida corretta per ogni molla al fine di ridurre la possibilità di deformazioni. Generalmente, se la lunghezza libera è più del quadruplo del diametro medio della molla, potrebbe sorgere un problema di deformazione quando questa viene compressa. Tale situazione può essere risolta mediante l'utilizzo di una barra di guida, la perforazione di una cavità o entrambe.

Sì: ingrandire le cavità delle molle proporzionalmente quando lo stampo viene affilato; si mantengono così la stessa corsa della molla e lo stesso livello di carico. Ogni cavità deve avere una base piatta e angoli quadrati in modo che la molla, quando viene compressa, possa imprimere una sollecitazione uniforme su ogni spira.

Sì: eseguite attività di manutenzione preventiva con una frequenza regolare e programmata. Prendete nota del numero di cicli eseguiti da ogni stampo e sostituite tutte le molle per stampi a intervalli stabiliti.

NON sostituite solo una molla e non mischiate molle di diverse lunghezze e gamme di deflessione nello stesso stampo. Invece di utilizzare un gruppo misto e non equilibrato di molle vecchie e nuove, sostituite tutte le molle per distribuire il carico uniformemente.

NON modificate una molla per stampi tagliando spire o affilando il diametro interno o esterno. Modificare una molla per stampi provoca un guasto precoce e mette a rischio lo stampo.

NON aspettatevi prestazioni di massima durata da una molla che funziona con un carico massimo. Nonostante le molle per stampi siano ideate per un funzionamento con un carico massimo, quando questo viene raggiunto la sollecitazione è elevata.

NON aspettate: incorporate la selezione della molla nella fase iniziale della progettazione e rispettate i limiti fisici. Conviene determinare quali e quante molle sono necessarie prima della costruzione dello stampo.

Sì: chiamateci! Il nostro esperto servizio di assistenza e i nostri ingegneri professionali sono sempre a disposizione per aiutarvi con qualsiasi quesito, da dimensioni personalizzate e materiali speciali a domande tecniche e applicazioni insolite.



APLICAÇÃO ADEQUADA DA MOLA DE MATRIZ

FAÇA da seleção da mola uma parte da função inicial do projeto, e trabalhe dentro dos limites físicos da mola. É melhor determinar quais e quantas molas são necessárias para o trabalho antes que a matriz seja construída.

PRÉ-CARREGUE cada mola na ferramenta e/ou instrumento montado para evitar a possibilidade de carga de choque, o que provoca um aumento na tensão na frequência de vibração e pode resultar em falha prematura da mola.

FORNEÇA salvaguardas de elementos externos adversos, tais como calor, atmosfera corrosiva, lascas de metal e outras obstruções.

FORNEÇA orientação adequada em todas as molas para reduzir a chance de deformação. Como regra geral, se o comprimento livre é mais de quatro vezes que o diâmetro médio da mola, pode haver um problema de deformação sob compressão. Isto é resolvido através do uso de uma haste de guia, perfuração de um furo, ou ambos.

APROFUNDE proporcionalmente os bolsos de mola quando a matriz/montagem está afiada para manter o mesmo nível de percurso e carga de mola. Cada bolso de mola precisa de ter um fundo plano e cantos quadrados, para que a mola forneça tensão uniforme em cada bobina, conforme seja comprimida.

REALIZE manutenção preventiva em maneira programada regularmente. Manter registros sobre o número de ciclos cada matriz desempenha, e substitua todas as molas de matriz em intervalos predeterminados.

NÃO substitua apenas uma mola, ou uma mistura de molas de comprimentos variados e faixas de desvio em uma matriz. Em vez de usar uma montagem desequilibrada e constituída de molas antigas e novas, substitua todas as molas para distribuir a carga uniformemente.

NÃO altere uma mola de matriz por meio de cortes de bobinas ou trituração do diâmetro externo ou interno. Alteração da mola de matriz provoca falha precoce e cria o potencial para danificar a ferramenta, montagem, matriz.

NÃO espere que um desempenho de vida útil máxima de uma mola que está produzindo a carga máxima. Embora molas de matriz sejam projetadas para produzir carga máxima, elas são altamente tensionadas quando atendem as cargas máximas.

NÃO espere - Faça a seleção da mola uma parte da função inicial do projeto, e trabalhe dentro dos limites físicos da mola. É melhor determinar quais e quantas molas são necessários para o trabalho antes que a matriz seja construída.

ENTRE em contato conosco - o nosso bem informado serviço ao cliente e profissionais de engenharia estão sempre disponíveis para ajudá-lo com tudo; de tamanhos personalizados e materiais especiais para questões técnicas e aplicações raras.





COMMON DIE SPRING TERMINOLOGY

HOLE DIAMETER

This identifies the outside diameter (H) of the die spring. Raymond die springs are available in eight different hole sizes matched to standard drill sizes. Each spring is made to fit in the hole, so the H of the spring is actually less than the hole diameter.

ROD DIAMETER

This is a nominal identification of the inside diameter (R) of the die spring. Raymond die springs are available in eight different hole sizes matched to standard stripper bolts. Each spring is made to fit over the rod, so the R of the springs is actually greater than the rod diameter.

FREE LENGTH

The length of a die spring before it is subject to any operating force or load.

PRELOAD

The distance the free length of the die spring is reduced by the pressure of assembled tool.

OPERATING TRAVEL

The distance which is subtracted from the spring length after operating force has been applied.

DEFLECTION

The amount of change in spring length after operating force has been applied. The compressed length is computed by subtracting the initial compression and the operating travel from the free length.

SOLID HEIGHT

The length of a spring when it is compressed by enough load to bring all the coils into contact with each other.

LOAD

This is the force built up by compressing the spring. Load is expressed in terms of total Newtons, which is the load on the spring per a specific unit of deflection. Load is generated and stress on the coils increases.



TERMINOLOGIE COMMUNE DES RESSORTS

LOGEMENT

Permet d'identifier le diamètre extérieur (H) du ressort d'outil de presse. Les ressorts en provenance de Raymond (USA) sont disponibles dans huit diamètres de logement différents qui s'adaptent aux dimensions standards des forêts. Chaque ressort est fabriqué pour rentrer dans le logement, par conséquent son Do est plus petit que le diamètre de logement.

AXE

Dimension nominale du diamètre intérieur (R) du ressort. Les ressorts en provenance de Raymond (USA) sont disponibles dans huit diamètres de logement différents qui s'adaptent aux dimensions standards des écrous. Chaque ressort est fabriqué pour s'adapter sur l'axe, par conséquent son Di est plus grand que le diamètre de l'axe.

LONGUEUR LIBRE

Longueur du ressort à l'état libre, avant toute compression.

PRECONTRAINTE

La longueur libre du ressort est réduite par la pression au montage.

COURSE DE TRAVAIL

Distance ée à la longueur libre après application de la charge.

DEFLEXION

Variation de la longueur du ressort après application de la charge de travail. La longueur comprimée est obtenue en soustrayant la compression initiale et la course de travail à la longueur libre.

HAUTEUR SOLIDE

Longueur du ressort une fois comprimé par une charge suffisante permettant aux spires d'être en contact l'une avec l'autre (hauteur à spires jointives).

CHARGE

Force obtenue en comprimant le ressort. La charge est exprimée en Newtons, ce qui correspond à la charge obtenue par le ressort à une certaine déflexion. La charge est générée et la tension augmente.



TERMINOLOGÍA PROPIA DE LOS MUELLES DE TROQUEL

DIÁMETRO DEL ORIFICIO

Permite identificar el diámetro exterior del muelle. Los muelles de troquel Raymond están disponibles en 8 tamaños de orificio diferentes que coinciden con los tamaños estándar de las brocas. Cada muelle está fabricado para encajar perfectamente en el orificio, por lo que el diámetro exterior del muelle es menor que el del orificio.

DIÁMETRO DE LA VARILLA

Identificación nominal del diámetro interior del muelle de troquel. Los muelles de troquel Raymond están disponibles en 8 tamaños de orificio diferentes que coinciden con los pernos eyectores estándares. Cada muelle está fabricado para que la varilla encaje perfectamente, por lo que el diámetro interior de los muelles es mayor que el de la varilla.

LONGITUD LIBRE

Longitud del muelle de troquel antes de ser sometido a ninguna operación de fuerza o carga.

CARGA PREVIA

La distancia en la que se reduce la longitud libre del muelle por la presión de una herramienta ensamblada.

CARRERA DE TRABAJO

La distancia sustraída de la longitud del muelle tras aplicar la carga.

DEFLEXIÓN

Variación de la longitud del muelle tras la aplicación de la carga de trabajo. La longitud comprimida se obtiene sustrayendo la compresión inicial y la carrera de trabajo a la longitud libre.

ALTURA SÓLIDA

Longitud del muelle una vez comprimido por una carga suficiente que permita que las espiras estén en contacto entre sí

CARGA

Fuerza que se obtiene al comprimir el muelle. La carga se expresa en newton, que corresponden a la carga obtenida por el muelle a una deflexión específica. Se genera la carga y aumenta la tensión.





ERKZEUGFEDERN – TERMINOLOGIE

HÜLSENDURCHMESSER

Dieser Begriff bezeichnet den Außendurchmesser (H) der Feder. Raymond Werkzeugfedern sind in acht verschiedenen Hülsendurchmessern erhältlich, welche Standard-Bohrergrößen entsprechen. Jede Feder wird so hergestellt, dass sie in die entsprechende Öffnung passt, so dass der Außendurchmesser der Feder tatsächlich geringer ist als der Hülsendurchmesser.

DORNDURCHMESSER

Dies ist eine Bezeichnung für den Innendurchmesser (R) der Werkzeugfeder. Raymond Werkzeugfedern sind in acht verschiedenen Hülsgrößen erhältlich, die Standard-Schaftschrauben entsprechen. Jede Feder wird so hergestellt, dass sie über den Dorn passt, so dass der Innendurchmesser der Federn tatsächlich größer ist als der Dorndurchmesser.

UNGESPANNTE LÄNGE

Die Länge einer Feder, bevor sie einer Kraft oder Last ausgesetzt wird.

VORSPANNUNG

Die Entfernung, in der die ungespannte Länge der Feder durch den Druck des Werkzeugs reduziert wird.

BETRIEBSWEG

Die Entfernung die von der Federlänge subtrahiert wird, nachdem die Betätigungskraft ausgeübt wurde.

FEDERWEG

Die Veränderung in der Federlänge, nachdem eine Betätigungskraft ausgeübt wurde. Die Drucklänge wird durch Subtrahieren des Feder-Ausgangsdrucks und des Arbeitswegs von der ungespannten Länge berechnet.

BLOCKLÄNGE

Die Länge einer Feder, wenn diese von einer Last so komprimiert wird, dass alle Windungen aneinander liegen.

KRAFT

Dies ist die Kraft, die durch das Zusammendrücken der Feder aufgebaut wird. Die Kraft wird in Newton ausgedrückt. Dies ist die Kraft der Feder für eine bestimmte Federwegeinheit. Es wird eine Kraft erzeugt und die Spannung der Windungen erhöht sich



TERMINOLOGIA COMUNE DELLE MOLLE PER STAMPI

DIAMETRO DEL FORO:

Identifi ca il diametro esterno (H) della molla. Le molle per stampi Raymond sono disponibili in otto differenti diametri del foro che si adattano perfettamente alle dimensioni standard delle punte foratrici. Ogni molla viene fabbricata in modo da essere inserita nel foro, in questo modo il diametro esterno della molla è inferiore a quello del diametro del foro.

DIAMETRO DEL PERNO:

Denominazione del diametro interno (R) della molla. Le molle per stampi Raymond sono disponibili in otto differenti diametri del foro che si adattano perfettamente alle dimensioni standard dei perni. Ogni molla viene fabbricata in modo da adattarsi perfettamente al perno, perciò il suo diametro interno è superiore a quello del perno.

LUNGHEZZA LIBERA:

La lunghezza di una molla per stampi prima di essere sottoposta a un'operazione di forza o carico.

PRECARICA:

La lunghezza libera viene ridotta dalla pressione del montaggio.

CORSA DI LAVORO:

La distanza sottratta dalla lunghezza della molla dopo l'applicazione di un carico.

DEFLESSIONE:

Variazione della lunghezza della molla dopo l'applicazione del carico. La lunghezza compressa si ottiene sottraendo la compressione iniziale e la corsa di lavoro alla lunghezza libera.

ALTEZZA A BLOCCO:

La lunghezza di una molla quando viene compressa da un carico sufficiente da mettere le spirali a contatto tra loro.

CARICO:

Forza generata dalla compressione della molla. Viene espresso in Newton e corrisponde alla forza ottenuta dalla molla a un certo livello di deflessione. Quando viene generato il carico la pressione aumenta.



TERMINOLOGIA TÍPICA DE MOLAS DE MATRIZ

DIÂMETRO DO FURO:

Identifi ca o diâmetro externo (H) da mola de matriz. As molas de matriz Raymond existem em oito diferentes tamanhos de furo que correspondem às dimensões padrão de brocas. Cada mola é fabricada para caber no furo, de maneira que o DE da mola seja efetivamente menor que o diâmetro do furo.

DIÂMETRO DA HASTE:

Esta é a identifi cação nominal do diâmetro interno (R) da mola de matriz. As molas de matriz Raymond existem em oito diferentes tamanhos de furo que correspondem às dimensões padrão de pinos extratores padrão. Cada mola é fabricada para envolver a haste, de maneira que o Di da mola seja efetivamente maior que o diâmetro da haste.

COMPRIMENTO LIVRE:

O comprimento de uma mola de matriz antes de estar sujeita a qualquer solicitação ou carga operacional.

PRÉ-CARGA:

A redução do comprimento de uma mola de matriz devido à pressão do ferramental montado.

PERCURSO DE OPERAÇÃO:

A distância subtraída do comprimento da mola depois de ser aplicada a força de acionamento.

DEFLEXÃO:

O valor da modi fi cação no comprimento da mola depois de ser aplicada a força do acionamento. O comprimento comprimido é calculado, subtraindo-se do comprimento livre a compressão original e o percurso de operação.

ALTURA SÓLIDA:

O comprimento da mola quando comprimida por uma carga sólida suficiente para todas as espirais se encostem uma nas outras.

CARGA:

Esta é a força acumulada pela compressão da mola. A carga é expressa em termos de um total de Newtons, que corresponde à carga sobre a mola por unidade específica de deflexão. Uma carga é gerada e aumenta a solicitação sobre as espirais de mola.





PROBLEMS AND ANSWERS

Most problems that arise in the use of die springs usually result from improper application... failure to take advantage of and protect the features engineered into the spring.

SPRING GUIDANCE

Raymond die springs are manufactured with ends ground and squared so that they stand on their own base and compress evenly under load. There is a positive relationship between the spring's outside diameter and total length which determines whether or not a spring will buckle under load.

Generally, if the free length is more than four times the mean diameter of the spring, it could have a buckling problem under compression. This is solved by providing guidance by a pocket, a rod, or both to reduce buckling. It is always recommended to provide guidance for any die spring.

TEMPERATURE

Heat is a frequently ignored factor in spring failure or load loss. The maximum rated service temperature for our chromium alloy steel is 230°C.

Thought should be given to the heat generated by the working die which can be significant in many applications. Heat absorbed by the tool can be transferred to the springs resulting in a loss of load and premature spring failure.

CORROSION

Frequently, spring failure can be traced to corrosive elements.

Reduction of material or pitting of the spring will reduce its useful life. Be alert to conditions that may affect the spring's surface such as rust, lubricants, soaps, chemicals, etc. Clean, protected springs give the best job performance.



PROBLÈMES ET SOLUTIONS

La majorité des problèmes qui apparaissent dans l'utilisation des ressorts d'outil de presse proviennent généralement d'une mauvaise utilisation.

GUIDAGE

Les ressorts "Raymond" sont fabriqués avec des extrémités rapprochées et meulées, de façon à ce qu'ils soient bien à plat une fois en position de travail, et que la pression soit appliquée sur toute la surface de la base. Il y a une relation positive entre le diamètre extérieur du ressort et la longueur totale, qui détermine si le ressort risque de se déformer sous charge.

Généralement, si la longueur libre est supérieure à 4 fois le diamètre moyen du ressort, il pourrait y avoir risque de déformation sous compression. Ce problème peut être résolu en guidant le ressort, soit par un logement, un axe, ou les deux. Il est toujours recommandé de guider le ressort pour une utilisation sans risque.

TEMPÉRATURE

La chaleur est un facteur fréquemment négligé. La température maximum que peut supporter un acier au Chrome Vanadium est de 230°C. L'attention est attirée sur la chaleur générée par la presse en action, qui peut être conséquente dans beaucoup d'applications.

La chaleur absorbée peut être transmise aux ressorts, ce qui peut provoquer une rupture prématurée du ressort.

CORROSION

Fréquemment les problèmes causés aux ressorts proviennent d'éléments corrosifs. La corrosion risque de limiter considérablement la durée de vie. Méfiez vous des environnements qui pourraient altérer le ressort, comme la rouille, les lubrifiants, détergents, produits chimiques, etc.

Des ressorts propres et bien protégés donnent la meilleure performance possible.



PROBLEMAS Y SOLUCIONES

La mayoría de los problemas que aparecen en la utilización de los muelles de troquel vienen provocados por la mala aplicación de los mismos.

GUÍA DEL MUELLE

Los muelles de troquel Raymond se fabrican con los extremos de sección transversal cuadrada, por lo que se sujetan sobre su propia base y se comprimen aún por de bajo de su carga. Existe una relación positiva entre el diámetro exterior del muelle y la longitud total, que es la que determina si el muelle corre el riesgo de deformarse o no con una carga inferior.

Como norma general, si la longitud libre es cuatro veces mayor que el diámetro medio del muelle, podría producirse la deformación bajo compresión. Para solucionarlo basta con guiarlo por una cavidad o una varilla o ambas opciones. Se recomienda siempre suministrar una guía para cualquier muelle de troquel.

TEMPERATURA

El calor es un problema que se ignora frecuentemente en el fallo del muelle o en la pérdida de carga. La temperatura máxima que puede soportar el acero al cromo de aleación es de 230°C. Llama

la atención el calor generado por el troquel en marcha que puede ser muy significativo en numerosas aplicaciones. El calor que absorbe la herramienta puede ser transferido a los muelles y de esta forma producirse una pérdida de carga y el fallo prematuro del muelle.

CORROSIÓN

Con frecuencia, los fallos del muelle se deben a elementos corrosivos. La corrosión reduce considerablemente la vida útil del muelle. Tenga cuidado con los productos que puedan modificar el muelle, tales como el óxido, los lubricantes, detergentes, productos químicos, etc. Los muelles limpios y protegidos proporcionan mejores resultados.





PROBLEME UND ANTWORTEN

Die meisten Probleme, die bei der Verwendung von Federn auftreten, sind gewöhnlich auf deren inkorrekten Einsatz oder die Nichtausnutzung ihrer integrierten Merkmale zurückzuführen.

FEDERFÜHRUNG

Raymond Werkzeugfedern werden mit geschliffenen und quadratischen Enden hergestellt, so dass sie auf ihrer eigenen Basis stehen und unter Belastung gleichmäßig komprimiert werden. Es besteht eine positive Beziehung zwischen dem Außendurchmesser der Feder und der Gesamtlänge, durch welche bestimmt wird, ob sich eine Feder unter der Last verformt oder nicht.

Im Allgemeinen gilt: Wenn die ungespannte Länge mehr als viermal dem mittleren Durchmesser der Feder entspricht, können unter Druck Verformungsprobleme auftreten. Dieses Problem wird gelöst, indem eine Führung (Ausparung, Stange oder beides) zur Verfügung gestellt wird, um die Verformung zu reduzieren. Es ist immer empfehlenswert, eine Führung für Werkzeugfedern zur Verfügung zu stellen.

TEMPERATUR

Wärme ist ein häufig ignorierter Faktor, der zum Versagen von Federn oder Kraftverlusten führt. Die maximale Nennbetriebstemperatur für unseren chromlegierten Stahl beträgt 230°C. Besondere Aufmerksamkeit sollte der vom Werkzeug erzeugten Wärme gewidmet werden, die bei vielen Anwendungen beträchtlich sein kann. Die vom Werkzeug aufgenommene Wärme kann auf die Federn übertragen werden, was zu Kraftverlusten und Federversagen führt.

KORROSION

Federversagen kann oft auf korrosive Elemente zurückgeführt werden. Materialschwund oder Rostfraß an der Feder reduzieren deren Lebensdauer. Achten Sie auf Bedingungen, die die Oberfläche der Feder beeinträchtigen können, wie Rost, Schmiermittel, Seife, Chemikalien usw. Saubere, geschützte Federn erzielen die besten Leistungen.



PROBLEMI E SOLUZIONI

La maggior parte dei problemi che scaturiscono nell'utilizzo delle molle per stampi sono generalmente provocati da errori di applicazione delle stesse.

GUIDA

Le molle Raymond hanno le estremità levigate e squadrate, in modo che, in posizione di lavoro, il carico eserciti la pressione su tutta la superficie della base. Esiste un rapporto positivo tra il diametro esterno della molla e la lunghezza totale, che determina il deformarsi o meno della molla quando si trova sotto carico.

Generalmente, se la lunghezza libera è quattro volte superior al diametro medio della molla, può sussistere un rischio di deformazione sotto compressione.

Questo problema può essere risolto guidando la molla lungo una cavità o un perno, o entrambi. E' consigliabile guidare sempre la molla per evitare rischi.

TEMPERATURA

Il calore è un fattore che viene spesso ignorato nella rottura di una molla o nella perdita del carico. La temperatura massima che l'acciaio al cromo può sopportare è di 230°C. Un dettaglio degno

di nota è il calore generato dallo stampo in azione, che può risultare significativo in molte applicazioni. Il calore assorbito può venire trasmesso alle molle, il che potrebbe provocare una rottura prematura della molla stessa.

CORROSIONE

Spesso i problemi sono causati anche da elementi corrosivi. La corrosione rischia di ridurre notevolmente il ciclo di vita delle molle. E' raccomandabile usare precauzione con gli agenti che potrebbero alterare la molla, quali ruggine, lubrificanti, detergenti e prodotti chimici. Per offrire i

risultati migliori le molle dovrebbero essere ben protette e in condizioni di pulizia ottimali.



PROBLEMAS E SOLUÇÕES

A maioria dos problemas que surgem na utilização de molas matriz é geralmente o resultado de uma aplicação imprópria ... Falhas na utilização e proteção das qualidades inerentes na fabricação da mola.

GUIAS PARA MOLAS

As molas Raymond são fabricadas com usinagem quadrada das extremidades, de modo que mantêm-se em pé sobre sua própria base e se comprimem uniformemente sob a carga. Existe uma relação positiva entre o diâmetro externo e o comprimento total de uma mola, o que determina se a mola irá deformar-se sob a carga.

Geralmente, se o comprimento livre for mais de quatro vezes o diâmetro médio da mola, ela poderá apresentar problemas de deformação sob compressão. A solução é proporcionar guias por meio de cavidade, uma haste, ou ambos para reduzir a deformação. É sempre recomendado proporcionar guias para qualquer mola matriz.

TEMPERATURA

O calor é um fator frequentemente desconsiderado na falha das molas ou na perda de carga. A temperatura máxima de serviço para o nosso aço cromo é 230°C. Deve ser considerado o calor gerado por uma matriz em serviço, o qual pode ser substancial em muitas aplicações. O calor absorvido pela ferramenta pode ser transferido às molas, resultando na perda de carga e falhas prematuras das molas.

CORROSÃO

Frequentemente, as falhas das molas podem ser o resultado de elementos corrosivos. A redução do material ou picagem por corrosão da mola pode reduzir a sua vida útil. Esteja alerta a condições que podem afetar a superfície da mola, tais como ferrugem, lubrificantes, detergentes, produtos químicos, etc. As molas limpas e protegidas proporcionam o melhor desempenho.





SELECTING DIE SPRINGS

A general rule to observe in spring selection is to always use as many springs as the die will accommodate which will produce the required load with the least amount of deflection. This will increase the useful life of the spring, reduce the chances of spring failure and the resulting downtime, loss of production and increased maintenance cost.

Die spring costs are a very small percentage of the total cost of the die. An effort to save a few pence on die springs is a misguided act that can cost many pounds in lost time and labour.

The more rapidly a spring works, the more attention must be paid to its fatigue limits. In slow moving dies or fixtures, it is possible to get good performance with springs operating near maximum deflection. As the working speed increases, the life expectancy of the spring at that deflection decreases.

Springs for strippers, pressure pads, and other die components can be selected from the following pages. When selecting a die spring it is necessary to determine the type of performance required of the springs: short, normal, or long run. For short or normal run applications use the deflections

tabulated in the long life columns. For long run applications use deflections based on optimum life. The recommended deflections for each spring based on the performance required are shown on the following pages.

Another approach when selecting a spring is to work back from the amount of operating travel the springs will be subjected to as indicated by the die layout. Select springs in the appropriate duty range which will operate efficiently at the required travel. Calculate the number of springs needed by dividing the load supplied by one spring into the total load required. Round the total number of springs to the next higher even number for balanced performance.

WEBSITE - ONLINE SELECTION

Our website now has a unique and invaluable selection tool - an innovative 'slide and select' feature that enables the customer to choose the parameters, dimensions, tolerances etc for a particular item. Then our system will automatically fine tune the product selection to one that most closely matches the specification and/or performance criteria required. Once the products are chosen, purchasing on-line is flexible, fast and accurate.

We are confident our new website will prove a reliable service that is very easy for any customer to use, whether a large scale professional engineer or small business, regardless of order size and however complex or precisely defined your requirements may be.



SÉLECTIONNER UN RESSORT D'OUTIL DE PRESSE

Une règle générale à observer dans le choix d'un ressort, est de toujours utiliser autant de ressorts que la matrice peut en adapter, ce qui fournira la charge recherchée avec une déflexion minimum. En découlera une augmentation de durée de vie du ressort et réduira les chances de rupture et d'arrêt de machines, de perte de production et d'augmentation de frais de maintenance.

Le coût d'un ressort d'outil de presse est un très petit pourcentage du coût total d'une matrice. Une économie de quelques centimes sur un ressort peut engendrer des coûts faramineux de temps et de main d'œuvre.

Plus un ressort travaille vite et plus il faut surveiller son taux de fatigue. Pour des cycles lents, il est possible d'obtenir une excellente performance avec des ressorts travaillant sur leur course maximale. Plus la vitesse de travail s'accroît, plus la durée de vie du ressort diminue.

Des ressorts pouvant aller sur des presses ou d'autres composants peuvent être sélectionnés dans les pages suivantes. Pour choisir un ressort d'outil de presse, il est nécessaire de déterminer le type de performance requise: court, moyen ou long terme. Pour des applications à court et moyen terme, utiliser les déflexions énoncées dans les colonnes longue vie. Pour des applications à long terme, utiliser les déflexions fondées sur la vie optimale. Les déflexions recommandées pour chaque ressort par rapport aux performances souhaitées sont indiquées aux pages suivantes.

Une autre approche pour choisir un ressort, est de prendre en considération le nombre de cycles que le ressort doit subir, comme précisé sur le tracé de la matrice. Sélectionner les ressorts dans la catégorie de charge appropriée pour un travail efficace à la course demandée. Calculer le nombre de ressorts nécessaire en divisant la charge totale voulue, par la charge fournie par un ressort. Arrondir le nombre total de ressorts au chiffre supérieur pour une performance idéale.

SITE INTERNET – SÉLECTION EN LIGNE

Notre nouveau site Web dispose d'un outil de sélection unique et très apprécié avec un nouveau menu déroulant permettant au client de sélectionner les paramètres, dimensions, tolérances etc. d'un article en particulier. Notre système affiche alors automatiquement une sélection de produits répondant à l'un ou tous les critères demandés relatifs aux spécifications et / ou performances requises. Une fois les produits sélectionnés, l'achat en ligne est à la fois flexible, rapide et précis.

Nous sommes convaincus de la fiabilité du service offert par ce nouveau site facile d'utilisation pour tous les clients, qu'il s'agisse de professionnels de l'ingénierie au profit de grands groupes ou de petites entreprises, quels que soient le nombre de pièces commandées, la complexité des articles ou encore la précision définie selon vos exigences.



SELECCIONAR UN MUELLE DE TROQUEL

Una regla general que hay que tener en cuenta a la hora de elegir un muelle es la de utilizar siempre tantos muelles como vaya a albergar el troquel que producirá la carga requerida con la menor cantidad de deflexión. Esto aumentará la vida útil del muelle, reducirá las posibilidades de fallo del muelle y el tiempo perdido que resulta de esto, así como las pérdidas productivas y los costes elevados de mantenimiento.

El muelle de troquel supone un porcentaje muy pequeño del coste del troquel. Ahorrar algo de dinero en los muelles resulta una elección equivocada que puede traer a largo plazo importantes costes en tiempo perdido y mano de obra.

Cuanto más rápido trabaja un muelle, más atención hay que prestar a sus límites de fatiga. En ciclos lentos, es posible obtener buenos resultados con los muelles trabajando cerca de la deflexión máxima. A medida que aumenta la velocidad, la vida útil del muelle disminuye.

Se pueden seleccionar los muelles para desmoldadoras, prensas y otros componentes de troquel de las páginas siguientes. Cuando se selecciona un muelle de troquel hay que determinar el tipo de resultados requeridos de los muelles: recorrido corto, normal o largo. Para aplicaciones de recorridos cortos o normales, se deben utilizar las deflexiones señaladas en la columna de larga vida. Para aplicaciones de recorrido largo, se deben utilizar las de la columna de vida óptima. Las deflexiones recomendadas para cada muelle basadas en los resultados requeridos se demostraron en las páginas siguientes.

Otro punto que se debe tener en cuenta a la hora de seleccionar un muelle es el de considerar el número de ciclos que el troquel requiere que realice el muelle. Hay que seleccionar los muelles en función de la labor que vayan a desempeñar para que funcionen de acuerdo con la carrera requerida. Hay que calcular el número de muelles necesarios dividiendo la carga total suministrada por un muelle entre la carga total requerida. Redondear el número resultante de muelles hacia el mayor para obtener los resultados requeridos.

PAGINA WEB SELECCION ONLINE

Esta nueva herramienta le mostrará las referencias que mejor se ajusten a sus criterios de selección. Una vez seleccionadas las referencias puede comprar y pagar online de una forma ágil y sencilla. Por supuesto siempre puede contactar con nosotros si quiere realizar el pedido por correo electrónico, fax o teléfono.

Estamos seguros de que esta nueva página web será muy fácil de usar para cualquier cliente, ya sea ingeniero o cualquier otro profesional en grandes empresas, Pymes o particulares, independientemente del tamaño del pedido y complejidad del mismo.





AUSWAHL VON WERKZEUGFEDERN

Als allgemeine Regel bei der Auswahl von Werkzeugfedern wird empfohlen, eine möglichst hohe Anzahl von Federn einzusetzen und die angegebenen Kräfte und Federwege nicht zu überschreiten.

Dies erhöht die Nutzungsdauer der Federn und reduziert das Risiko eines Federausfalls und der damit verbundenen Ausfallzeiten Produktionsverluste und erhöhten Wartungskosten.

Die Kosten für die Federn stellen nur einen geringen Anteil der Gesamtkosten für das Werkzeug dar. Es ist eine falsche Sparsamkeit, bei der Auswahl von Werkzeugfedern einige Cents einsparen zu wollen, da dies letztendlich zu hohen Zeit- und Arbeitskraftverlusten und damit Ertragseinbußen führen kann. Je schneller eine Feder arbeitet, desto mehr Aufmerksamkeit muss ihrer Dauerfestigkeit gewidmet werden. Bei langsamen Werkzeugen oder Vorrichtungen kann man eine gute Leistung mit Federn mit fast maximalen Federwegen erzielen. Bei einer erhöhten Betriebsgeschwindigkeit nimmt die Lebenserwartung der Feder bei diesen Federwegen ab.

Auf den folgenden Seiten können Sie Federn für Abstreifer, Druckkissen und andere Werkzeugkomponenten auswählen. Bei der Auswahl einer Werkzeugfeder muss die von den Federn

erwartete Leistung bestimmt werden: kurzzeitig, normal oder für einen längeren Einsatz. Für kurze und normale Einsätze sollten die in den Spalten für eine lange Lebensdauer aufgeführten Federwege verwendet werden. Für langfristige Anwendungen werden Federwege basierend auf der optimalen Lebensdauer verwendet. Die empfohlenen Federwege für jede Feder je nach der erforderlichen Leistung werden auf den folgenden Seiten angezeigt.

Eine andere Methode bei der Auswahl einer Feder ist die Verwendung des Arbeitsweges, dem die Federn ausgesetzt werden (anhand der Werkzeugzeichnung zu bestimmen). Wählen Sie Federn in der entsprechenden Belastungsklasse aus, die bei dem erforderlichen Arbeitsweg effizient arbeiten. Berechnen Sie die Anzahl der benötigten Federn, indem Sie die von einer Feder zur Verfügung gestellte Kraft durch die erforderliche Gesamtkraft teilen. Runden Sie die Gesamtzahl der Federn zur nächsten geraden Zahl ab, um eine ausgeglichene Leistung zu gewährleisten.

WEBSEITE: ONLINE AUSWAHL

Unsere Webseite verfügt jetzt über ein einzigartiges und wertvolles Selektions-Tool: eine innovative „Schieben und Wählen“ Eigenschaft, die dem Kunden ermöglicht die Parameter, Dimensionen, Toleranzwerte u.s.w. für einen speziellen Artikel zu wählen. Unser System wird dann automatisch die Produktauswahl feiner einstellen auf einen Grad, welcher der Spezifikation, bzw. dem erforderlichen Leistungskriterium am besten entspricht. Nachdem die Produkte ausgewählt sind, ist der Online Kauf flexibel, schnell und präzise.

Wir sind zuversichtlich, dass unsere neue Webseite einen zuverlässigen Service bietet, der sehr einfach für Kunden zu benutzen ist, ob von großen Spezialunternehmen oder Kleinfirmen, unabhängig von der Auftragsgröße oder wie komplex oder präzise definiert Ihre Anforderungen auch sein mögen.



SCEGLIERE LE MOLLE PER STAMPI

Una regola generale da seguire nella scelta delle molle è quella di utilizzare sempre il numero di molle che lo stampo potrà ospitare, il che produrrà il carico richiesto con la minima defl. essione. Questo allungherà il ciclo di vita della molla, ridurrà le possibilità di rottura della stessa e del conseguente tempo passivo, della perdita di produzione e dei costi elevati di manutenzione.

Il costo delle molle per stampi costituiscono una piccolo percentuale del costo totale dello stampo. Il risparmio di qualche centesimo su una molla potrebbe comportare un notevole spreco di tempo e manodopera.

Quanto più rapidamente lavora una molla, tanto più è necessario prestare attenzione ai suoi limiti di tensione. Nei cicli lenti, è possibile ottenere ottimi risultati con molle che lavorano al livello massimo di defl. essione. Man mano che aumenta la velocità il ciclo di vita delle molle diminuisce.

Nelle pagine seguenti è possibile scegliere molle per presse e altri componenti. Quando si sceglie una molla per stampi è necessario determinare il tipo di performance richiesta: ciclo breve, normale o lungo. Per le applicazioni a ciclo breve o medio si utilizzano le defl. essioni segnalate nella Colonna del ciclo di vita. Le defl. essioni consigliate per ogni molla in relazione ai risultati desiderati sono elencate nelle pagine seguenti.

Un altro dettaglio da considerare nella scelta di una molla è il numero di cicli che la molla stessa dovrà effettuare, come indicato sullo stampo. Selezionare le molle appartenenti alla categoria di carico appropriato affinché funzionino in modo efficiente a seconda del risultato desiderato. Calcolare il numero di molle necessarie dividendo il carico totale per il carico fornito da una sola molla. Arrotondare per eccesso il numero complessivo delle molle per ottenere un risultato ottimale.

SITO WEB – SELEZIONE ONLINE

Il nostro sito Web ora dispone di uno strumento di selezione unico e prezioso: una funzione innovativa in stile “scorri e seleziona”, che consente a ogni cliente di scegliere i parametri, le dimensioni, le tolleranze ecc. per un determinato prodotto. Il nostro sistema esegue poi una regolazione automatica al fine di trovare gli articoli che assomigliano il più possibile a quelli desiderati, ovvero che presentano le caratteristiche tecniche e/o i criteri prestazionali selezionati. A scelta effettuata, acquistare i prodotti online è un'opzione flessibile, veloce e precisa.

Siamo certi che il nostro nuovo sito Web si rivelerà essere un servizio affidabile e facilissimo da usare per tutti, che si tratti di ingegneri professionali della grande distribuzione o di piccole aziende, indipendentemente dalla quantità di prodotti ordinati e dalla complessità o minuziosità dei propri requisiti.



SELEÇÃO DE MOLAS DE MATRIZ

Uma regra geral para seleção de molas é sempre usar o número máximo de molas comportadas pela matriz e que produza a carga exigida com o mínimo de defl. exão. Isto aumentará a vida útil da mola, reduzirá a possibilidade de falha da mola e dos resultantes tempos de parada, perdas na produção e aumentos nas despesas de manutenção.

As despesas das molas de matriz constituem uma porcentagem muito pequena do custo total da matriz. Uma pequena economia nas molas matriz pode ser um ato malorientado que pode resultar em grandes gastos de tempo perdido e mão-de-obra.

Quando mais rápido o funcionamento de uma mola, mais atenção deve ser prestada aos seus limites de fadiga. Para matrizes ou dispositivos de acionamento lento, é possível obter um bom desempenho com molas que operam próximo à sua defl. exão máxima. Ao aumentar-se a velocidade de acionamento, diminui a vida útil da mola, com a mesma defl. exão.

Molas para extratores, coxins de pressão, e outros componentes de matrizes podem ser selecionadas nas seguintes páginas. Ao selecionar uma mola de matriz, é necessário determinar o tipo de desempenho esperado da mola: curso curto, médio ou longo. Para aplicações de curso curto ou médio, use as defl. exões tabuladas nas colunas para vida longa. Para aplicações de curso longo, use as defl. exões baseadas em vida máxima. As defl. exões recomendadas para cada mola, com base no desempenho exigido, aparecem nas páginas abaixo.

Outro método de seleção de uma mola é calcular primeiro o valor do curso operacional a que as molas estarão sujeitas, conforme indicado no layout da matriz. Seleccione as molas na faixa apropriada de serviço que operarão eficientemente no curso exigido. Calcule o número necessário de molas, dividindo a carga total exigida pela carga proporcionada por uma só mola. Arredonde o número de molas até o número par mais alto para obter um desempenho equilibrado.

WEBSITE – SELEÇÃO ONLINE

Este site agora possui uma nova ferramenta inovadora que melhor se ajusta a seus critérios de seleção. O recurso “deslize e seleccione” permite ao cliente escolher os parâmetros, dimensões e tolerâncias para um determinado item. Em seguida, nosso sistema irá ajustar automaticamente a seleção do produto a que mais se aproxima da especificação e/ou critérios de desempenho exigidos. Uma vez selecionados os produtos pode-se efetuar a compra on line de forma rápida e precisa.

Este novo site irá proporcionar um serviço de confiança e de fácil utilização à todos os clientes e empresas, independentemente do tamanho e complexidade das suas necessidades e exigências.





KEY TO DIMENSIONS

ISO, NAMMS, JIS

- H** = Hole Diameter (mm)
- R** = Rod Diameter (mm)
- Lo** = Free Length (mm)
- P/f** = Spring Rate (N/mm)
- L1** = Optimum operating deflection (mm)
- L2** = Mid operating deflection (mm)
- L3** = Maximum operating deflection (mm)
- L4** = Maximum deflection (mm)
- N** = Force (N)
- D** = Deflection (mm)

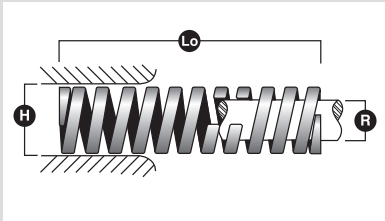

⚠ Deflection values shown represent compressed lengths near solid and are for design information only. It is not recommended using the spring at this deflection value.

INDEX DES DIMENSIONS

ISO, NAMMS, JIS

- H** = Diamètre de Logement (mm)
- R** = Diamètre d'Axe (mm)
- Lo** = Longueur Libre (mm)
- P/f** = Raideur du Ressort (N/mm)
- L1** = Déflexion minimum de fonctionnement (mm)
- L2** = Déflexion moyenne de fonctionnement (mm)
- L3** = Déflexion maximum de fonctionnement (mm)
- L4** = Déflexion maximum
- N** = Force / Charge (N)
- D** = Déflexion (mm)

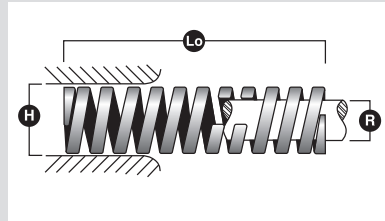

⚠ Les valeurs de déflexion indiquées représentent des longueurs en charge proches des longueurs à bloc et sont pour information uniquement. Il n'est pas recommandé d'utiliser les ressorts à ces déflexions.

CLAVES DE CARACTERÍSTICAS

ISO, NAMMS, JIS

- H** = Diámetro agujero (mm)
- R** = Diámetro eje (mm)
- Lo** = Altura libre (mm)
- P/f** = Ratio de fuerza (N/mm)
- L1** = Deflexión operativa óptima (mm)
- L2** = Deflexión operativa media (mm)
- L3** = Deflexión operativa máxima (mm)
- L4** = Deflexión máxima (mm)
- N** = Fuerza (N)
- D** = Deflexión (mm)

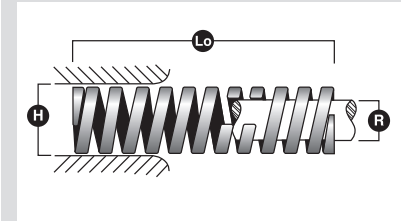

⚠ Carga a altura sólida, exclusivamente como información. No se recomienda utilizar el muelle a esa carga.

ISO 10243 SERIES

Duty	Colour	Pages
Super Light Duty	Light green	14-15
Light Duty	Green	16-17
Medium Duty	Blue	18-19
Heavy Duty	Red	20-21
Extra Heavy Duty	Yellow	22-23
Super Heavy Duty	Silver	24-25

NAMMS SERIES

Duty	Colour	Pages
Medium Duty	Blue	26-27
Medium Heavy Duty	Red	28-29
Heavy Duty	Gold	30-31
Extra Heavy Duty	Green	32-33

JIS B 5012 SERIES

Duty	Colour	Pages
Extra Light Duty	Yellow	34-39
Light Duty	Blue	40-45
Medium Duty	Red	46-51
Heavy Duty	Green	52-56
Extra Heavy Duty	Brown	57-61

ISO 10243 SERIES

Charge	Couleur	Pages
Super Légère	Vert clair	14-15
Légère	Vert	16-17
Moyenne	Bleu	18-19
Forte	Rouge	20-21
Extra Forte	Jaune	22-23
Super Extra Forte	Argent	24-25

NAMMS SERIES

Charge	Couleur	Pages
Moyenne	Bleu	26-27
Mi-Forte	Rouge	28-29
Forte	Or	30-31
Extra-Forte	Vert	32-33

JIS B 5012 SERIES

Charge	Couleur	Pages
Super Légère	Jaune	34-39
Légère	Bleu	40-45
Moyenne	Rouge	46-51
Forte	Vert	52-56
Extra Forte	Marron	57-61

ISO 10243 SERIES

Carga	Color	Paginas
Super Ligera	Verde claro	14-15
Ligera	Verde	16-17
Media	Azul	18-19
Fuerte	Rojo	20-21
Extra Fuerte	Amarillo	22-23
Super Fuerte	Plata	24-25

NAMMS SERIES

Carga	Color	Paginas
Media	Azul	26-27
Media Fuerte	Rojo	28-29
Fuerte	Oro	30-31
Extra Fuerte	Verde	32-33

JIS B 5012 SERIES

Carga	Color	Paginas
Super Ligera	Amarillo	34-39
Ligera	Azul	40-45
Media	Rojo	46-51
Fuerte	Verde	52-56
Extra Fuerte	Marrón	57-61





ABMESSUNGEN

ISO, NAMMS, JIS

- H = Hülsendurchmesser (mm)
- R = Dorndurchmesser (mm)
- Lo = Ungespannte Länge (mm)
- P/f = Federrate (N/mm)
- L1 = Optimaler Betriebsfederweg (mm)
- L2 = Mittlerer Federweg (mm)
- L3 = Maximaler Betriebsfederweg (mm)
- L4 = Maximaler Federweg (mm)
- N = Kraft (N)
- D = Federweg (mm)

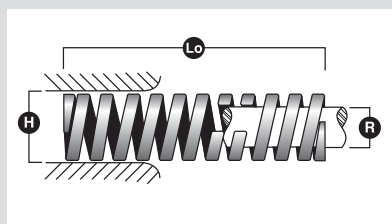

⚠ Die angezeigten Durchfederungswerte repräsentieren die komprimierte Länge im soliden Bereich und dienen nur als Designinformationen. Es wird nicht empfohlen die Feder bei diesem Durchfederungswert zu benutzen.

LEGENDA

ISO, NAMMS, JIS

- H = Diametro sede (mm)
- R = Diametro perno (mm)
- Lo = Lunghezza libera (mm)
- P/f = Carico flessionale unitario (N/mm)
- L1 = Deflessione ottimale di lavoro (mm)
- L2 = Deflessione media di lavoro (mm)
- L3 = Deflessione massimo di lavoro (mm)
- L4 = Massima deflessione (mm)
- N = Forza (N)
- D = Deflessione (mm)

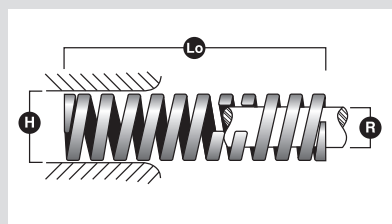

⚠ I valori di deflessione indicati rappresentano lunghezze compresse quasi a blocco e sono presentati a puro scopo informativo. Non si consiglia un utilizzo della molla a tale valore di deflessione.

LEGENDA

ISO, NAMMS, JIS

- H = Diâmetro do furo
- R = Diâmetro da haste
- Lo = Comprimento livre
- P/f = Taxa de compressão da mola
- L1 = Ponto de defl exão para vida longa
- L2 = Ponto de defl exão media
- L3 = Ponto de defl exão Máxima
- L4 = Máximo de defl exão
- N = Força (N)
- D = Deflexão (mm)

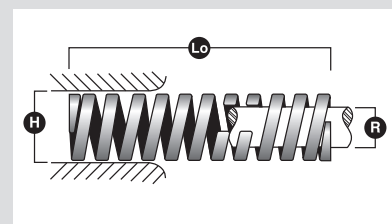

⚠ Os valores de deflexão mostrados representam tamanhos quando comprimidos próximo a altura sólida e são somente para informações para projetos.

ISO 10243 SERIE

Stärke	Farbe	Seite
Super Leichte Beanspruchung	Hellgrün	12-13
Geringe Beanspruchung	Grün	14-15
Mittlere Beanspruchung	Rot	16-17
Starke Beanspruchung	Grün	18-19
Extra Starke Beanspruchung	Braun	20-21
Super Schwere Beanspruchung	Silber	22-23

ISO 10243 SERIE

Carico	Colore	Pagine
Carico super leggero	Verde chiaro	12-13
Carico leggero	Verde	14-15
Carico medio	Blu	16-17
Carico pesante	Rosso	18-19
Carico extra pesante	Giallo	20-21
Carico super pesante	Argento	22-23

ISO 10243 SÉRIE

Carga	Cor	Páginas
Carga Super Leve	Verde claro	12-13
Carga Leve	Verde	14-15
Carga Média	Azul	16-17
Carga Pesada	Vermelho	18-19
Carga Extra Pesada	Amarelo	20-21
Carga Super Pesada	Prata	22-23

NAMMS SERIE

Stärke	Farbe	Seite
Mittlere Beanspruchung	Blau	24-25
Mittlere Beanspruchung	Rot	26-27
Starke Beanspruchung	Grün	28-29
Extra Starke Beanspruchung	Braun	30-31

NAMMS SERIE

Carico	Colore	Pagine
Carico medio	Blu	24-25
Carico medio pesante	Rosso	26-27
Carico pesante	Oro	28-29
Carico extra pesante	Verde	30-31

NAMMS SÉRIE

Carga	Cor	Páginas
Carga Média	Azul	24-25
Carga Pesada Media	Vermelho	26-27
Carga Pesada	Dourado	28-29
Carga Extra Pesada	Verde	30-31

JIS B 5012 SERIE

Stärke	Farbe	Seite
Extra Leichte Beanspruchung	Gelb	32-36
Geringe Beanspruchung	Blau	38-42
Mittlere Beanspruchung	Rot	44-48
Starke Beanspruchung	Grün	50-54
Extra Starke Beanspruchung	Braun	56-60

JIS B 5012 SERIE

Carico	Colore	Pagine
Carico extra leggero	Giallo	32-36
Carico leggero	Blu	38-42
Carico medio	Rosso	44-48
Carico pesante	Verde	50-54
Carico extra pesante	Marrone	56-60

JIS B 5012 SÉRIE

Carga	Cor	Páginas
Carga Super Leve	Amarelo	32-36
Carga Leve	Azul	38-42
Carga Média	Vermelho	44-48
Carga Pesada	Verde	50-54
Carga Extra Pesada	Marron	56-60



ISO 10243 SERIES



SUPER LIGHT DUTY ISO COLOUR CODED **LIGHT GREEN**

CHARGE SUPER LÉGÈRE NORME ISO COULEUR **VERT CLAIR**

CARGA SUPER LIGEROS **VERDE CLARO** CÓDIGO COLOR SEGÚN ISO

SUPER LEICHTE BEANSPRUCHUNG ISO FARBUNTERLEGTES **HELLGRÜN**

CARICO SUPER LEGGERO CODICE CROMATICO ISO **VERDE CHIARO**

CARGA SUPER LEVE COR **VERDE CLARO** (ISO)

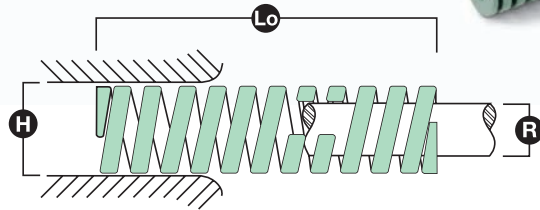

H	R	Lo	Part No.	P/f	L ₁ 30%		L ₂ 40%		L ₃ 50%		L ₄ ⚠	
					N	D	N	D	N	D	N	D
20.0	10.0	25	302-404-D	29.4	221	7.5	294	10.0	368	12.5	488	16.6
		32	302-405-D	22.6	217	9.6	289	12.8	362	16.0	488	21.6
		38	302-406-D	18.6	212	11.4	283	15.2	353	19.0	476	25.6
		44	302-407-D	15.7	207	13.2	276	17.6	345	22.0	468	29.8
		51	302-408-D	13.7	210	15.3	279	20.4	349	25.5	478	34.9
		64	302-410-D	11.3	217	19.2	289	25.6	362	32.0	507	44.9
		76	302-412-D	9.8	223	22.8	298	30.4	372	38.0	530	54.1
		89	302-414-D	8.3	222	26.7	295	35.6	369	44.5	526	63.4
		102	302-416-D	7.4	226	30.6	302	40.8	377	51.0	544	73.5
		114	302-418-D	6.4	219	34.2	292	45.6	365	57.0	521	81.4
		127	302-420-D	5.9	225	38.1	300	50.8	375	63.5	542	91.9
		140	302-422-D	5.4	227	42.0	302	56.0	378	70.0	549	101.6
		152	302-424-D	4.9	223	45.6	298	60.8	372	76.0	539	109.9
305	302-448-D	2.5	229	91.5	305	122.0	381	152.5	556	222.5		
25.0	12.5	25	302-504-D	53.9	404	7.5	539	10.0	674	12.5	782	14.5
		32	302-505-D	42.2	405	9.6	540	12.8	675	16.0	806	19.1
		38	302-506-D	35.8	408	11.4	544	15.2	680	19.0	831	23.2
		44	302-507-D	31.4	414	13.2	553	17.6	691	22.0	860	27.4
		51	302-508-D	27.0	413	15.3	551	20.4	689	25.5	869	32.2
		64	302-510-D	21.6	415	19.2	553	25.6	691	32.0	886	41.0
		76	302-512-D	18.1	413	22.8	550	30.4	688	38.0	889	49.1
		89	302-514-D	15.2	406	26.7	541	35.6	676	44.5	869	57.2
		102	302-516-D	13.2	404	30.6	539	40.8	673	51.0	870	65.9
		114	302-518-D	11.8	404	34.2	538	45.6	673	57.0	870	73.7
		127	302-520-D	10.6	404	38.1	538	50.8	673	63.5	878	82.8
		140	302-522-D	9.6	403	42.0	538	56.0	672	70.0	876	91.3
		152	302-524-D	8.8	401	45.6	535	60.8	669	76.0	869	98.8
178	302-528-D	7.6	406	53.4	541	71.2	676	89.0	885	116.4		
203	302-532-D	6.7	408	60.9	544	81.2	680	101.5	895	133.6		
305	302-548-D	4.4	403	91.5	537	122.0	671	152.5	884	200.8		
32.0	16.0	38	302-606-D	43.1	491	11.4	655	15.2	819	19.0	1065	24.7
		44	302-607-D	37.3	492	13.2	656	17.6	821	22.0	1082	29.0
		51	302-608-D	32.4	496	15.3	661	20.4	826	25.5	1105	34.1
		64	302-610-D	25.5	490	19.2	653	25.6	816	32.0	1107	43.4
		76	302-612-D	21.6	492	22.8	657	30.4	821	38.0	1128	52.2
		89	302-614-D	18.1	483	26.7	644	35.6	805	44.5	1102	60.9
		102	302-616-D	15.7	480	30.6	641	40.8	801	51.0	1099	70.0
		114	302-618-D	14.2	486	34.2	648	45.6	809	57.0	1115	78.5
		127	302-620-D	12.7	484	38.1	645	50.8	806	63.5	1118	88.0
		140	302-622-D	11.6	487	42.0	650	56.0	812	70.0	1131	97.5
		152	302-624-D	10.6	483	45.6	644	60.8	806	76.0	1120	105.7
		178	302-628-D	9.0	481	53.4	641	71.2	801	89.0	1113	123.7
		203	302-632-D	7.8	475	60.9	633	81.2	792	101.5	1100	141.0
254	302-640-D	6.4	488	76.2	650	101.6	813	127.0	1146	179.0		
305	302-648-D	5.3	485	91.5	647	122.0	808	152.5	1140	215.0		
40.0	20.0	51	302-708-D	48.1	736	15.3	981	20.4	1227	25.5	1481	30.8
		64	302-710-D	39.2	753	19.2	1004	25.6	1254	32.0	1560	39.8
		76	302-712-D	33.3	759	22.8	1012	30.4	1265	38.0	1602	48.1
		89	302-714-D	28.4	758	26.7	1011	35.6	1264	44.5	1613	56.8
		102	302-716-D	24.5	750	30.6	1000	40.8	1250	51.0	1588	64.8
		114	302-718-D	22.1	756	34.2	1008	45.6	1260	57.0	1622	73.4
		127	302-720-D	19.6	747	38.1	996	50.8	1245	63.5	1601	81.7
		140	302-722-D	17.7	743	42.0	991	56.0	1239	70.0	1595	90.1
		152	302-724-D	16.2	739	45.6	985	60.8	1231	76.0	1583	97.7
		178	302-728-D	13.7	732	53.4	975	71.2	1219	89.0	1567	114.4
		203	302-732-D	12.3	749	60.9	999	81.2	1248	101.5	1630	132.5
		254	302-740-D	9.8	747	76.2	996	101.6	1245	127.0	1631	166.4
		305	302-748-D	8.3	759	91.5	1013	122.0	1266	152.5	1676	201.9

ISO



ISO 10243 SERIES

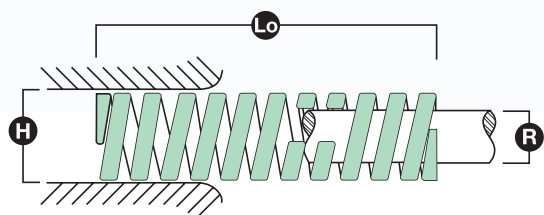

H	R	Lo	Part No.	P/f	L ₁ 30%		L ₂ 40%		L ₃ 50%		L ₄ ⚠	
					N	D	N	D	N	D	N	D
50.0	25.0	64	302-810-D	86.3	1657	19.2	2209	25.6	2762	32.0	3461	40.1
		76	302-812-D	70.6	1610	22.8	2146	30.4	2683	38.0	3382	47.9
		89	302-814-D	59.8	1597	26.7	2129	35.6	2661	44.5	3373	56.4
		102	302-816-D	52.0	1591	30.6	2122	40.8	2652	51.0	3390	65.2
		114	302-818-D	46.1	1577	34.2	2102	45.6	2628	57.0	3379	73.3
		127	302-820-D	42.2	1608	38.1	2144	50.8	2680	63.5	3482	82.5
		140	302-822-D	38.2	1604	42.0	2139	56.0	2674	70.0	3503	91.7
		152	302-824-D	34.3	1564	45.6	2085	60.8	2607	76.0	3375	98.4
		178	302-828-D	29.4	1570	53.4	2093	71.2	2617	89.0	3410	116.0
		203	302-832-D	25.5	1553	60.9	2071	81.2	2588	101.5	3376	132.4
		254	302-840-D	20.6	1570	76.2	2093	101.6	2616	127.0	3459	167.9
		305	302-848-D	17.2	1574	91.5	2098	122.0	2623	152.5	3483	202.5

ISO



ISO 10243 SERIES



LIGHT DUTY ISO COLOUR CODED **GREEN**

CHARGE LÉGÈRE NORME ISO COULEUR **VERTE**

CARGA LIGERA **VERDE** CÓDIGO COLOR SEGÚN ISO

GERINGE BEANSPRUCHUNG ISO FARBUNTERLEGTES **GRÜN**

CARICHI LEGGERI COLORE **VERDE** SECONDO NORMA ISO

CARGA LEVE **COR VERDE** (ISO)

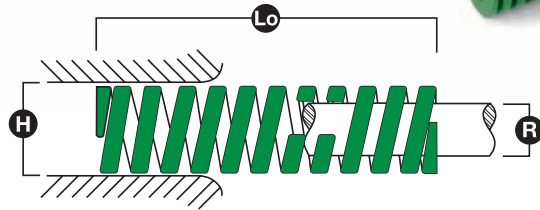

H	R	Lo	Part No.	P/f	L ₁ 25%		L ₂ 30%		L ₃ 40%		L ₄ ⚠	
					N	D	N	D	N	D	N	D
10.0	5.0	25	303-104-D	12.2	76	6.3	92	7.5	122	10.0	165	13.5
		32	303-105-D	9.9	79	8.0	95	9.6	127	12.8	174	17.5
		38	303-106-D	8.2	78	9.5	94	11.4	125	15.2	171	20.8
		44	303-107-D	6.4	71	11.0	85	13.2	113	17.6	155	24.1
		51	303-108-D	6.3	80	12.8	96	15.3	129	20.4	182	28.9
		64	303-110-D	5.3	85	16.0	102	19.2	135	25.6	198	37.5
		76	303-112-D	4.3	81	19.0	97	22.8	129	30.4	184	43.4
		305	303-148-D	1.0	79	76.3	95	91.5	127	122.0	185	178.0
12.5	7.0	25	303-204-D	18.6	116	6.3	139	7.5	186	10.0	292	15.7
		32	303-205-D	14.9	119	8.0	143	9.6	190	12.8	309	20.8
		38	303-206-D	12.7	121	9.5	145	11.4	194	15.2	321	25.2
		44	303-207-D	11.1	123	11.0	147	13.2	196	17.6	329	29.5
		51	303-208-D	9.3	118	12.8	142	15.3	190	20.4	315	33.9
		64	303-210-D	7.2	115	16.0	138	19.2	184	25.6	305	42.4
		76	303-212-D	5.9	112	19.0	134	22.8	178	30.4	292	49.8
		89	303-214-D	4.7	105	22.3	127	26.7	169	35.6	270	57.0
		102	303-216-D	4.1	105	25.5	125	30.6	167	40.8	239	58.4
		305	303-248-D	1.4	104	76.3	124	91.5	166	122.0	268	196.9
16.0	8.5	25	303-304-D	31.7	198	6.3	238	7.5	317	10.0	441	13.9
		32	303-305-D	23.2	186	8.0	223	9.6	297	12.8	409	17.6
		38	303-306-D	20.5	195	9.5	234	11.4	312	15.2	449	21.9
		44	303-307-D	17.9	197	11.0	236	13.2	315	17.6	461	25.8
		51	303-308-D	15.5	198	12.8	237	15.3	316	20.4	470	30.3
		64	303-310-D	12.7	203	16.0	243	19.2	325	25.6	496	39.1
		76	303-312-D	10.0	189	19.0	227	22.8	303	30.4	446	44.8
		89	303-314-D	8.9	199	22.3	239	26.7	318	35.6	486	54.4
		102	303-316-D	7.6	193	25.5	232	30.6	309	40.8	486	64.1
		114	303-318-D	6.6	188	28.5	226	34.2	301	45.6	401	60.8
		305	303-348-D	2.6	195	76.3	234	91.5	312	122.0	484	188.9
20.0	10.0	25	303-404-D	55.4	346	6.3	415	7.5	554	10.0	742	13.4
		32	303-405-D	43.4	347	8.0	416	9.6	555	12.8	772	17.8
		38	303-406-D	34.4	327	9.5	392	11.4	523	15.2	712	20.7
		44	303-407-D	27.7	305	11.0	366	13.2	488	17.6	637	23.0
		51	303-408-D	24.9	318	12.8	381	15.3	509	20.4	623	25.0
		64	303-410-D	18.8	301	16.0	361	19.2	482	25.6	643	34.2
		76	303-412-D	16.1	306	19.0	367	22.8	489	30.4	667	41.5
		89	303-414-D	13.1	292	22.3	350	26.7	467	35.6	619	47.2
		102	303-416-D	11.9	303	25.5	363	30.6	484	40.8	666	56.1
		114	303-418-D	11.0	315	28.5	378	34.2	504	45.6	717	65.4
		127	303-420-D	9.4	298	31.8	358	38.1	478	50.8	665	70.7
		140	303-422-D	8.6	298	35.0	357	42.0	476	56.0	664	77.5
		152	303-424-D	7.6	287	38.0	344	45.6	459	60.8	612	81.1
		305	303-448-D	3.8	291	76.3	350	91.5	466	122.0	648	169.6
25.0	12.5	25	303-504-D	103.1	644	6.3	773	7.5	1031	10.0	1361	13.2
		32	303-505-D	80.7	646	8.0	775	9.6	1033	12.8	1420	17.6
		38	303-506-D	64.6	613	9.5	736	11.4	981	15.2	1336	20.7
		44	303-507-D	53.8	592	11.0	710	13.2	947	17.6	1280	23.8
		51	303-508-D	45.8	584	12.8	701	15.3	935	20.4	1260	27.5
		64	303-510-D	35.7	571	16.0	685	19.2	914	25.6	1246	34.9
		76	303-512-D	28.6	542	19.0	651	22.8	868	30.4	1151	40.3
		89	303-514-D	24.8	551	22.3	661	26.7	881	35.6	1193	48.2
		102	303-516-D	20.6	526	25.5	631	30.6	841	40.8	1105	53.6
		114	303-518-D	18.6	534	28.5	640	34.2	854	45.6	1141	61.5
		127	303-520-D	16.7	530	31.8	636	38.1	847	50.8	1131	67.8
		140	303-522-D	14.6	506	35.0	607	42.0	810	56.0	1041	71.5
		152	303-524-D	13.6	518	38.0	621	45.6	828	60.8	1091	80.1
		178	303-528-D	11.8	524	44.5	629	53.4	839	71.2	1123	95.3
		203	303-532-D	10.6	535	50.8	642	60.9	857	81.2	1170	110.9
305	303-548-D	6.8	515	76.3	618	91.5	824	122.0	1098	162.6		



ISO 10243 SERIES

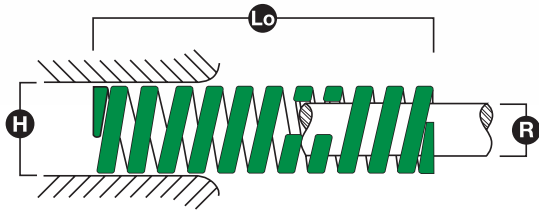

H	R	Lo	Part No.	P/f	L ₁ 25%		L ₂ 30%		L ₃ 40%		L ₄ ⚠	
					N	D	N	D	N	D	N	D
32.0	16.0	38	303-606-D	91.8	872	9.5	1046	11.4	1395	15.2	2230	24.3
		44	303-607-D	83.2	915	11.0	1098	13.2	1464	17.6	2305	27.7
		51	303-608-D	70.6	901	12.8	1081	15.3	1441	20.4	2289	32.4
		64	303-610-D	55.1	881	16.0	1057	19.2	1410	25.6	2257	41.0
		76	303-612-D	45.7	868	19.0	1041	22.8	1388	30.4	2233	48.9
		89	303-614-D	38.6	859	22.3	1031	26.7	1374	35.6	2220	57.5
		102	303-616-D	33.7	860	25.5	1032	30.6	1376	40.8	2240	66.4
		114	303-618-D	30.0	861	28.5	1033	34.2	1378	45.6	2255	75.3
		127	303-620-D	25.8	820	31.8	984	38.1	1312	50.8	2102	81.4
		140	303-622-D	23.8	826	35.0	991	42.0	1322	56.0	2135	89.8
		152	303-624-D	21.7	825	38.0	990	45.6	1319	60.8	2135	98.4
		178	303-628-D	17.6	784	44.5	941	53.4	1255	71.2	1986	112.7
		203	303-632-D	15.6	792	50.8	950	60.9	1267	81.2	2022	129.6
		254	303-640-D	12.6	799	63.5	959	76.2	1279	101.6	2062	163.8
305	303-648-D	9.6	732	76.3	878	91.5	1171	122.0	1801	187.6		
40.0	20.0	51	303-708-D	104.6	1333	12.8	1600	15.3	2133	20.4	2667	25.5
		64	303-710-D	79.6	1273	16.0	1528	19.2	2037	25.6	2506	31.5
		76	303-712-D	66.6	1264	19.0	1517	22.8	2023	30.4	2522	37.9
		89	303-714-D	57.2	1272	22.3	1527	26.7	2036	35.6	2596	45.4
		102	303-716-D	48.6	1239	25.5	1487	30.6	1982	40.8	2497	51.4
		114	303-718-D	43.2	1243	28.5	1491	34.2	1989	45.6	2538	58.7
		127	303-720-D	39.2	1245	31.8	1494	38.1	1992	50.8	2560	65.3
		140	303-722-D	35.0	1215	35.0	1458	42.0	1944	56.0	2462	70.4
		152	303-724-D	31.7	1206	38.0	1447	45.6	1929	60.8	2437	76.8
		178	303-728-D	27.3	1215	44.5	1458	53.4	1944	71.2	2493	91.3
		203	303-732-D	23.5	1191	50.8	1429	60.9	1905	81.2	2412	102.8
		254	303-740-D	18.9	1198	63.5	1438	76.2	1917	101.6	2461	130.4
305	303-748-D	15.5	1179	76.3	1415	91.5	1886	122.0	2412	156.0		
50.0	25.0	64	303-810-D	148.6	2377	16.0	2853	19.2	3804	25.6	6166	41.5
		76	303-812-D	125.2	2378	19.0	2853	22.8	3805	30.4	5782	46.2
		89	303-814-D	104.5	2324	22.3	2789	26.7	3719	35.6	5641	54.0
		102	303-816-D	90.4	2304	25.5	2765	30.6	3687	40.8	5629	62.3
		114	303-818-D	78.7	2261	28.5	2714	34.2	3618	45.6	5514	70.1
		127	303-820-D	70.4	2235	31.8	2681	38.1	3575	50.8	5447	77.4
		140	303-822-D	63.1	2192	35.0	2630	42.0	3507	56.0	5311	84.2
		152	303-824-D	56.9	2163	38.0	2595	45.6	3460	60.8	5224	91.8
		178	303-828-D	48.6	2164	44.5	2597	53.4	3462	71.2	5271	108.4
		203	303-832-D	41.8	2121	50.8	2545	60.9	3393	81.2	5132	122.8
		254	303-840-D	35.7	2264	63.5	2717	76.2	3623	101.6	5734	160.8
		305	303-848-D	26.8	2040	76.3	2448	91.5	3264	122.0	4879	182.4
63.0	38.0	76	303-912-D	191.2	3633	19.0	4359	22.8	5812	30.4	7036	36.8
		89	303-914-D	157.5	3503	22.3	4204	26.7	5605	35.6	6833	43.4
		102	303-916-D	136.1	3471	25.5	4165	30.6	5553	40.8	6819	50.1
		114	303-918-D	118.1	3395	28.5	4074	34.2	5432	45.6	6648	56.3
		127	303-920-D	105.7	3355	31.8	4026	38.1	5368	50.8	6625	62.7
		152	303-924-D	86.3	3281	38.0	3937	45.6	5249	60.8	6657	77.1
		178	303-928-D	73.7	3278	44.5	3934	53.4	5245	71.2	6792	92.2
		203	303-932-D	63.2	3209	50.8	3851	60.9	5134	81.2	6513	103.0
		254	303-940-D	49.9	3167	63.5	3800	76.2	5067	101.6	6483	130.0
		305	303-948-D	41.0	3124	76.3	3749	91.5	4998	122.0	6432	157.0

ISO



ISO 10243 SERIES



MEDIUM DUTY ISO COLOUR CODED **BLUE**

CHARGE MOYENNE NORME ISO COULEUR **BLEUE**

CARGA MEDIA **AZUL** CÓDIGO COLOR SEGÚN ISO

MITTLERE BEANSPRUCHUNG ISO FARBUNTERLEGTES **BLAU**

CARICHI MEDI COLORE **BLU** SECONDO NORMA ISO

CARGA MEDIA **COR AZUL** (ISO)

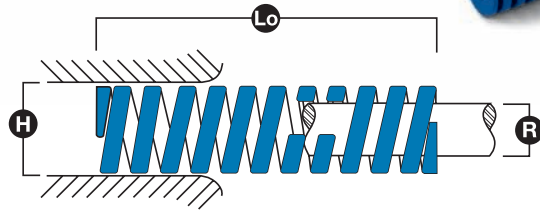

H	R	Lo	Part No.	P/f	L ₁ 25%		L ₂ 30%		L ₃ 40%		L ₄ ⚠	
					N	D	N	D	N	D	N	D
10.0	5.0	25	304-104-D	15.7	98	6.3	117	7.5	157	10.0	188	12.0
		32	304-105-D	13.5	108	8.0	130	9.6	173	12.8	233	17.2
		38	304-106-D	11.7	111	9.5	133	11.4	177	15.2	246	21.1
		44	304-107-D	9.6	105	11.0	127	13.2	169	17.6	227	23.7
		51	304-108-D	8.6	110	12.8	132	15.3	176	20.4	247	28.6
		64	304-110-D	6.6	106	16.0	127	19.2	169	25.6	233	35.2
		76	304-112-D	5.5	105	19.0	126	22.8	168	30.4	230	41.7
305	304-148-D	1.4	103	76.3	124	91.5	165	122.0	229	169.4		
12.5	7.0	25	304-204-D	29.4	184	6.3	220	7.5	294	10.0	376	12.8
		32	304-205-D	22.5	180	8.0	216	9.6	287	12.8	373	16.6
		38	304-206-D	18.7	178	9.5	213	11.4	284	15.2	372	19.9
		44	304-207-D	15.9	175	11.0	210	13.2	280	17.6	366	23.0
		51	304-208-D	13.7	175	12.8	210	15.3	280	20.4	371	27.0
		64	304-210-D	10.5	167	16.0	201	19.2	268	25.6	345	33.0
		76	304-212-D	8.7	165	19.0	198	22.8	264	30.4	338	39.0
		89	304-214-D	7.5	166	22.3	200	26.7	266	35.6	347	46.4
		102	304-216-D	6.3	161	25.5	193	30.6	257	40.8	329	52.3
305	304-248-D	2.2	164	76.3	197	91.5	262	122.0	347	161.2		
16.0	8.5	25	304-304-D	55.7	348	6.3	418	7.5	557	10.0	646	11.6
		32	304-305-D	40.0	320	8.0	384	9.6	512	12.8	568	14.2
		38	304-306-D	34.7	329	9.5	395	11.4	527	15.2	617	17.8
		44	304-307-D	30.6	336	11.0	404	13.2	538	17.6	655	21.4
		51	304-308-D	26.6	339	12.8	406	15.3	542	20.4	672	25.3
		64	304-310-D	20.8	333	16.0	399	19.2	532	25.6	661	31.8
		76	304-312-D	17.8	339	19.0	407	22.8	542	30.4	692	38.8
		89	304-314-D	15.0	335	22.3	402	26.7	535	35.6	681	45.3
		102	304-316-D	13.3	339	25.5	406	30.6	542	40.8	701	52.8
		114	304-318-D	11.8	336	28.5	404	34.2	538	45.6	627	53.1
		305	304-348-D	4.2	319	76.3	383	91.5	511	122.0	644	153.8
20.0	10.0	25	304-404-D	91.0	569	6.3	682	7.5	910	10.0	955	10.5
		32	304-405-D	67.9	543	8.0	652	9.6	869	12.8	944	13.9
		38	304-406-D	55.1	524	9.5	629	11.4	838	15.2	915	16.6
		44	304-407-D	46.7	513	11.0	616	13.2	821	17.6	877	18.8
		51	304-408-D	39.9	509	12.8	611	15.3	814	20.4	922	23.1
		64	304-410-D	30.8	493	16.0	592	19.2	790	25.6	848	27.5
		76	304-412-D	25.7	488	19.0	586	22.8	781	30.4	869	33.8
		89	304-414-D	22.1	491	22.3	590	26.7	786	35.6	877	39.7
		102	304-416-D	19.4	494	25.5	592	30.6	790	40.8	916	47.3
		115	304-418-D	17.0	488	28.8	586	34.5	781	46.0	891	52.5
		127	304-420-D	15.3	485	31.8	583	38.1	777	50.8	870	56.9
		139	304-422-D	14.1	490	34.8	588	41.7	785	55.6	876	62.1
		152	304-424-D	12.8	486	38.0	583	45.6	777	60.8	864	67.6
		305	304-448-D	6.4	489	76.3	587	91.5	782	122.0	917	143.0
25.0	12.5	25	304-504-D	171.5	1072	6.3	1286	7.5	1715	10.0	1749	10.2
		32	304-505-D	126.5	1012	8.0	1214	9.6	1619	12.8	1733	13.7
		38	304-506-D	104.2	990	9.5	1188	11.4	1584	15.2	1637	15.7
		44	304-507-D	89.1	980	11.0	1176	13.2	1567	17.6	1639	18.4
		51	304-508-D	74.6	951	12.8	1141	15.3	1521	20.4	1618	21.7
		64	304-510-D	57.3	916	16.0	1099	19.2	1466	25.6	1489	26.0
		76	304-512-D	49.0	930	19.0	1116	22.8	1488	30.4	1581	32.3
		89	304-514-D	40.8	909	22.3	1090	26.7	1454	35.6	1552	38.0
		102	304-516-D	35.7	911	25.5	1093	30.6	1457	40.8	1540	43.1
		115	304-518-D	31.7	910	28.8	1092	34.5	1456	46.0	1551	49.0
		127	304-520-D	28.5	905	31.8	1086	38.1	1448	50.8	1539	54.0
		139	304-522-D	26.3	913	34.8	1096	41.7	1461	55.6	1579	60.1
		152	304-524-D	23.8	903	38.0	1083	45.6	1444	60.8	1544	65.0
		178	304-528-D	20.1	896	44.5	1075	53.4	1433	71.2	1542	76.6
		203	304-532-D	17.6	895	50.8	1074	60.9	1432	81.2	1559	88.4
		305	304-548-D	11.6	882	76.3	1059	91.5	1412	122.0	1562	135.0



ISO 10243 SERIES

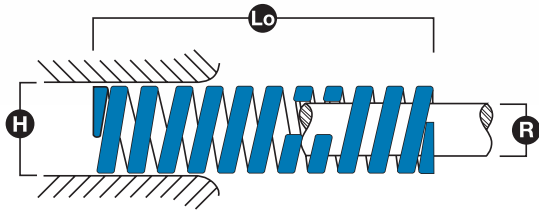

H	R	Lo	Part No.	P/f	L ₁ 25%		L ₂ 30%		L ₃ 40%		L ₄	
					N	D	N	D	N	D	N	D
32.0	16.0	38	304-606-D	166.8	1585	9.5	1902	11.4	2536	15.2	2903	17.4
		44	304-607-D	136.4	1500	11.0	1800	13.2	2400	17.6	2686	19.7
		51	304-608-D	116.2	1482	12.8	1778	15.3	2371	20.4	2697	23.2
		64	304-610-D	87.5	1401	16.0	1681	19.2	2241	25.6	2495	28.5
		76	304-612-D	70.9	1347	19.0	1617	22.8	2156	30.4	2425	34.2
		89	304-614-D	60.4	1343	22.3	1611	26.7	2148	35.6	2438	40.4
		102	304-616-D	51.6	1315	25.5	1578	30.6	2104	40.8	2475	48.0
		115	304-618-D	45.8	1315	28.8	1578	34.5	2105	46.0	4964	108.5
		127	304-620-D	41.7	1324	31.8	1589	38.1	2119	50.8	2469	59.2
		139	304-622-D	37.8	1314	34.8	1577	41.7	2103	55.6	2470	65.3
		152	304-624-D	33.8	1283	38.0	1539	45.6	2053	60.8	2464	73.0
		178	304-628-D	28.9	1288	44.5	1545	53.4	2061	71.2	2445	84.5
		203	304-632-D	24.9	1263	50.8	1515	60.9	2020	81.2	2411	96.9
		254	304-640-D	20.0	1268	63.5	1522	76.2	2029	101.6	2416	121.0
305	304-648-D	16.7	1272	76.3	1526	91.5	2035	122.0	2452	147.0		
40.0	20.0	51	304-708-D	170.3	2172	12.8	2606	15.3	3475	20.4	3645	21.4
		64	304-710-D	128.7	2059	16.0	2471	19.2	3295	25.6	3449	26.8
		76	304-712-D	107.3	2038	19.0	2445	22.8	3260	30.4	3507	32.7
		89	304-714-D	89.1	1982	22.3	2379	26.7	3172	35.6	3475	39.0
		102	304-716-D	75.5	1926	25.5	2312	30.6	3082	40.8	3331	44.1
		115	304-718-D	66.8	1921	28.8	2305	34.5	3074	46.0	3381	50.6
		127	304-720-D	61.0	1935	31.8	2323	38.1	3097	50.8	3408	55.9
		139	304-722-D	55.3	1923	34.8	2307	41.7	3076	55.6	3419	61.8
		152	304-724-D	50.8	1930	38.0	2316	45.6	3089	60.8	3429	67.5
		178	304-728-D	43.0	1914	44.5	2297	53.4	3062	71.2	3320	77.2
		203	304-732-D	37.4	1896	50.8	2275	60.9	3034	81.2	3430	91.8
		254	304-740-D	30.1	1909	63.5	2291	76.2	3054	101.6	3397	113.0
305	304-748-D	24.8	1887	76.3	2265	91.5	3020	122.0	3416	138.0		
50.0	25.0	64	304-810-D	211.8	3389	16.0	4067	19.2	5423	25.6	5974	28.2
		76	304-812-D	166.2	3158	19.0	3789	22.8	5052	30.4	5800	34.9
		89	304-814-D	139.4	3102	22.3	3722	26.7	4963	35.6	5464	39.2
		102	304-816-D	121.4	3095	25.5	3714	30.6	4952	40.8	5741	47.3
		115	304-818-D	107.0	3075	28.8	3690	34.5	4920	46.0	5626	52.6
		127	304-820-D	94.8	3009	31.8	3610	38.1	4814	50.8	5667	59.8
		139	304-822-D	86.4	3003	34.8	3604	41.7	4806	55.6	5627	65.1
		152	304-824-D	78.3	2975	38.0	3570	45.6	4759	60.8	5542	70.8
		178	304-828-D	65.9	2931	44.5	3517	53.4	4690	71.2	5546	84.2
		203	304-832-D	57.2	2901	50.8	3481	60.9	4641	81.2	5516	96.5
		229	304-836-D	50.8	2911	57.3	3493	68.7	4657	91.6	5491	108.0
		254	304-840-D	46.0	2919	63.5	3503	76.2	4671	101.6	5608	122.0
305	304-848-D	37.9	2891	76.3	3469	91.5	4625	122.0	5573	147.0		
63.0	38.0	76	304-912-D	303.5	5767	19.0	6920	22.8	9227	30.4	10199	33.6
		89	304-914-D	247.4	5506	22.3	6607	26.7	8809	35.6	9650	39.0
		102	304-916-D	210.8	5375	25.5	6450	30.6	8600	40.8	9464	44.9
		115	304-918-D	183.6	5278	28.8	6334	34.5	8445	46.0	9326	50.8
		127	304-920-D	162.6	5163	31.8	6195	38.1	8260	50.8	9041	55.6
		152	304-924-D	132.4	5029	38.0	6035	45.6	8047	60.8	8788	66.4
		178	304-928-D	111.1	4942	44.5	5930	53.4	7907	71.2	8629	77.7
		203	304-932-D	96.9	4916	50.8	5899	60.9	7866	81.2	8660	89.4
		229	304-936-D	85.9	4918	57.3	5901	68.7	7868	91.6	8934	104.0
		254	304-940-D	77.4	4917	63.5	5900	76.2	7867	101.6	8835	114.1
		305	304-948-D	64.1	4890	76.3	5868	91.5	7824	122.0	8850	138.0

ISO



ISO 10243 SERIES



HEAVY DUTY ISO COLOUR CODED **RED**

CHARGE FORTE NORME ISO COULEUR **ROUGE**

CARGA FUERTE **ROJO** CÓDIGO COLOR SEGÚN ISO

STARKE BEANSPRUCHUNG ISO FARBUNTERLEGTES **ROT**

CARICHI FORTI COLORE **ROSSO** SECONDO NORMA ISO

CARGA PESADA COR **VERMELHA** (ISO)



H	R	Lo	Part No.	P/f	L ₁ 20%		L ₂ 25%		L ₃ 30%		L ₄ ⚠	
					N	D	N	D	N	D	N	D
10.0	5.0	25	305-104-D	23.4	117	5.0	146	6.3	175	7.5	222	9.5
		32	305-105-D	18.0	115	6.4	144	8.0	172	9.6	221	12.3
		38	305-106-D	16.6	126	7.6	158	9.5	189	11.4	279	16.8
		44	305-107-D	14.5	127	8.8	159	11.0	191	13.2	288	19.9
		51	305-108-D	12.0	122	10.2	153	12.8	183	15.3	266	22.2
		64	305-110-D	9.9	126	12.8	158	16.0	189	19.2	290	29.4
		76	305-112-D	7.9	120	15.2	150	19.0	179	22.8	260	33.1
		305	305-148-D	1.9	118	61.0	147	76.3	177	91.5	260	134.5
12.5	7.0	25	305-204-D	42.4	212	5.0	265	6.3	318	7.5	475	11.2
		32	305-205-D	31.8	203	6.4	254	8.0	305	9.6	455	14.3
		38	305-206-D	27.1	206	7.6	257	9.5	308	11.4	476	17.6
		44	305-207-D	23.8	209	8.8	261	11.0	314	13.2	499	21.0
		51	305-208-D	19.9	203	10.2	254	12.8	305	15.3	479	24.0
		64	305-210-D	15.2	194	12.8	243	16.0	291	19.2	443	29.2
		76	305-212-D	13.5	204	15.2	256	19.0	307	22.8	498	37.0
		89	305-214-D	11.1	197	17.8	246	22.3	295	26.7	465	42.0
		102	305-216-D	8.4	171	20.4	214	25.5	257	30.6	368	43.8
		305	305-248-D	3.2	192	61.0	240	76.3	288	91.5	458	145.4
16.0	8.5	25	305-304-D	78.0	390	5.0	487	6.3	585	7.5	741	9.5
		32	305-305-D	61.0	390	6.4	488	8.0	586	9.6	787	12.9
		38	305-306-D	50.7	385	7.6	482	9.5	578	11.4	786	15.5
		44	305-307-D	45.5	400	8.8	501	11.0	601	13.2	874	19.2
		51	305-308-D	36.9	377	10.2	471	12.8	565	15.3	779	21.1
		64	305-310-D	29.4	377	12.8	471	16.0	565	19.2	798	27.1
		76	305-312-D	25.7	390	15.2	488	19.0	585	22.8	875	34.1
		89	305-314-D	21.8	388	17.8	485	22.3	582	26.7	875	40.1
		102	305-316-D	18.9	386	20.4	482	25.5	579	30.6	870	46.0
		114	305-318-D	15.7	358	22.8	447	28.5	537	34.2	691	44.0
		305	305-348-D	6.2	375	61.0	469	76.3	563	91.5	849	138.0
20.0	10.0	25	305-404-D	219.2	1096	5.0	1370	6.3	1644	7.5	1819	8.3
		32	305-405-D	171.3	1097	6.4	1371	8.0	1645	9.6	1885	11.0
		38	305-406-D	136.6	1038	7.6	1298	9.5	1557	11.4	1721	12.6
		44	305-407-D	116.3	1024	8.8	1280	11.0	1536	13.2	1745	15.0
		51	305-408-D	96.7	986	10.2	1232	12.8	1479	15.3	1701	17.6
		64	305-410-D	74.2	950	12.8	1187	16.0	1425	19.2	1677	22.6
		76	305-412-D	62.8	955	15.2	1194	19.0	1433	22.8	1728	27.5
		89	305-414-D	53.9	959	17.8	1198	22.3	1438	26.7	1707	31.7
		102	305-416-D	46.5	949	20.4	1187	25.5	1424	30.6	1745	37.5
		114	305-418-D	41.9	963	22.8	1204	28.5	1445	34.2	1784	42.6
		127	305-420-D	37.3	948	25.4	1185	31.8	1422	38.1	1698	45.5
		140	305-422-D	33.9	942	28.0	1177	35.0	1413	42.0	1697	50.1
		152	305-424-D	30.9	939	30.4	1174	38.0	1409	45.6	1724	55.8
		305	305-448-D	15.2	927	61.0	1159	76.3	1391	91.5	1733	114.0
25.0	12.5	25	305-504-D	371.4	1857	5.0	2321	6.3	2785	7.5	3157	8.5
		32	305-505-D	280.7	1796	6.4	2246	8.0	2695	9.6	3088	11.0
		38	305-506-D	219.5	1668	7.6	2085	9.5	2502	11.4	2765	12.6
		44	305-507-D	201.3	1771	8.8	2214	11.0	2657	13.2	3100	15.4
		51	305-508-D	163.1	1664	10.2	2080	12.8	2495	15.3	2919	17.9
		64	305-510-D	127.1	1626	12.8	2033	16.0	2440	19.2	2935	23.1
		76	305-512-D	107.3	1631	15.2	2039	19.0	2446	22.8	2822	26.3
		89	305-514-D	90.1	1603	17.8	2004	22.3	2405	26.7	2747	30.5
		102	305-516-D	78.4	1599	20.4	1998	25.5	2398	30.6	2923	37.3
		114	305-518-D	70.6	1624	22.8	2029	28.5	2435	34.2	2958	41.9
		127	305-520-D	63.2	1605	25.4	2007	31.8	2408	38.1	2920	46.2
		140	305-522-D	57.5	1598	28.0	1997	35.0	2397	42.0	2834	49.3
		152	305-524-D	53.1	1613	30.4	2016	38.0	2420	45.6	2955	55.7
		178	305-528-D	45.2	1609	35.6	2012	44.5	2414	53.4	2943	65.1
		203	305-532-D	39.5	1602	40.6	2002	50.8	2403	60.9	2939	74.5
		305	305-548-D	26.8	1632	61.0	2040	76.3	2449	91.5	3136	117.2



ISO 10243 SERIES



H	R	Lo	Part No.	P/f	L ₁ 20%		L ₂ 25%		L ₃ 30%		L ₄ ⚠	
					N	D	N	D	N	D	N	D
32.0	16.0	38	305-606-D	387.2	2943	7.6	3678	9.5	4414	11.4	4879	12.6
		44	305-607-D	313.0	2754	8.8	3443	11.0	4131	13.2	4664	14.9
		51	305-608-D	267.5	2728	10.2	3410	12.8	4092	15.3	4761	17.8
		64	305-610-D	204.3	2615	12.8	3269	16.0	3923	19.2	4577	22.4
		76	305-612-D	171.7	2609	15.2	3261	19.0	3914	22.8	4480	26.1
		89	305-614-D	141.5	2518	17.8	3147	22.3	3777	26.7	4357	30.8
		102	305-616-D	123.6	2522	20.4	3152	25.5	3783	30.6	4549	36.8
		114	305-618-D	109.8	2525	22.8	3156	28.5	3787	34.2	4545	41.4
		127	305-620-D	98.7	2508	25.4	3135	31.8	3762	38.1	4384	44.4
		140	305-622-D	89.2	2478	28.0	3098	35.0	3718	42.0	4324	48.5
		152	305-624-D	81.7	2484	30.4	3105	38.0	3726	45.6	4478	54.8
		178	305-628-D	69.2	2465	35.6	3081	44.5	3697	53.4	4403	63.6
		203	305-632-D	60.7	2463	40.6	3078	50.8	3694	60.9	4398	72.5
		254	305-640-D	48.4	2458	50.8	3073	63.5	3687	76.2	4491	92.8
305	305-648-D	40.2	2452	61.0	3064	76.3	3677	91.5	4501	112.0		
40.0	20.0	51	305-708-D	371.7	3791	10.2	4739	12.8	5686	15.3	6318	17.0
		64	305-710-D	300.1	3841	12.8	4801	16.0	5761	19.2	6961	23.2
		76	305-712-D	233.6	3551	15.2	4439	19.0	5326	22.8	6237	26.7
		89	305-714-D	197.0	3507	17.8	4384	22.3	5260	26.7	6167	31.3
		102	305-716-D	170.3	3475	20.4	4344	25.5	5212	30.6	6320	37.1
		114	305-718-D	155.7	3582	22.8	4478	28.5	5373	34.2	6603	42.4
		127	305-720-D	137.4	3490	25.4	4363	31.8	5236	38.1	6390	46.5
		140	305-722-D	123.4	3431	28.0	4289	35.0	5147	42.0	6554	53.1
		152	305-724-D	114.4	3477	30.4	4346	38.0	5215	45.6	6416	56.1
		178	305-728-D	96.8	3445	35.6	4306	44.5	5167	53.4	6522	67.4
		203	305-732-D	84.7	3440	40.6	4300	50.8	5160	60.9	6456	76.2
		254	305-740-D	67.6	3433	50.8	4291	63.5	5149	76.2	6500	96.2
305	305-748-D	56.2	3428	61.0	4285	76.3	5142	91.5	6474	115.2		
50.0	25.0	64	305-810-D	424.3	5431	12.8	6788	16.0	8146	19.2	9800	23.1
		76	305-812-D	335.1	5094	15.2	6367	19.0	7640	22.8	8880	26.5
		89	305-814-D	276.8	4927	17.8	6159	22.3	7391	26.7	8720	31.5
		102	305-816-D	244.9	4996	20.4	6244	25.5	7493	30.6	9207	37.6
		114	305-818-D	214.6	4936	22.8	6170	28.5	7404	34.2	9164	42.7
		127	305-820-D	189.1	4804	25.4	6005	31.8	7205	38.1	8983	47.5
		140	305-822-D	169.0	4699	28.0	5874	35.0	7049	42.0	8756	51.8
		152	305-824-D	154.0	4683	30.4	5854	38.0	7024	45.6	8904	57.8
		178	305-828-D	130.8	4658	35.6	5822	44.5	6986	53.4	8962	68.5
		203	305-832-D	115.1	4671	40.6	5839	50.8	7007	60.9	8929	77.6
		254	305-840-D	90.5	4598	50.8	5748	63.5	6898	76.2	8862	97.9
305	305-848-D	75.5	4606	61.0	5757	76.3	6908	91.5	9136	121.0		
63.0	38.0	76	305-912-D	516.6	7852	15.2	9815	19.0	-	-	12760	24.7
		89	305-914-D	515	9167	17.8	11459	22.3	-	-	15450	30.0
		102	305-916-D	438	8935	20.4	11169	25.5	-	-	15374	35.1
		114	305-918-D	370	8436	22.8	10545	28.5	-	-	13875	37.5
		127	305-920-D	333	8458	25.4	10573	31.8	-	-	15285	45.9
		152	305-924-D	269	8178	30.4	10222	38.0	-	-	15199	56.5
		178	305-928-D	226	8046	35.6	10057	44.5	-	-	15097	66.8
		203	305-932-D	198	8039	40.6	10049	50.8	-	-	15602	78.8
		229	305-936-D	143.6	6577	45.8	8221	57.3	-	-	12307	85.7
		254	305-940-D	155	7874	50.8	9843	63.5	-	-	15810	102.0
		305	305-948-D	128	7808	61.0	9760	76.3	-	-	15616	122.0

ISO



ISO 10243 SERIES



EXTRA HEAVY DUTY ISO COLOUR CODED **YELLOW**

CHARGE EXTRA FORTE NORME ISO COULEUR **JAUNE**

CARGA EXTRA FUERTE **AMARILLO** CÓDIGO COLOR SEGÚN ISO

EXTRA STARKE BEANSPRUCHUNG ISO FARBUNTERLEGTES **GELB**

CARICHI EXTRA FORTI COLORE **GIALLO** SECONDO NORMA ISO

CARGA EXTRA PESADA COR **AMARELA** (ISO)

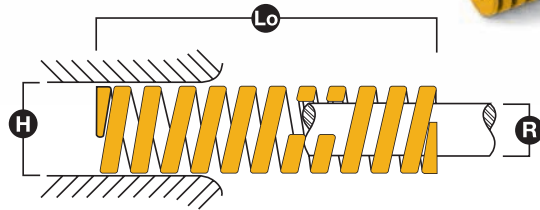

H	R	Lo	Part No.	P/f	L ₁ 17%		L ₂ 20%		L ₃ 25%		L ₄ ⚠	
					N	D	N	D	N	D	N	D
10.0	5.0	25	306-104-D	36.4	155	4.3	182	5.0	228	6.3	280	7.7
		32	306-105-D	27.5	149	5.4	176	6.4	220	8.0	291	10.6
		38	306-106-D	23.3	150	6.5	177	7.6	221	9.5	293	12.6
		44	306-107-D	19.6	147	7.5	173	8.8	216	11.0	271	13.8
		51	306-108-D	16.8	146	8.7	171	10.2	214	12.8	272	16.2
		64	306-110-D	13.3	145	10.9	170	12.8	213	16.0	271	20.4
		76	306-112-D	11.2	144	12.9	169	15.2	212	19.0	281	25.2
305	306-148-D	2.7	141	51.9	166	61.0	207	76.3	302	111.0		
12.5	7.0	25	306-204-D	54.7	233	4.3	274	5.0	342	6.3	487	8.9
		32	306-205-D	42.4	230	5.4	271	6.4	339	8.0	540	12.8
		38	306-306-D	34.6	223	6.5	263	7.6	328	9.5	480	13.9
		44	306-207-D	27.8	208	7.5	245	8.8	306	11.0	459	16.5
		51	306-208-D	25.3	219	8.7	258	10.2	322	12.8	477	18.9
		64	306-210-D	19.9	217	10.9	255	12.8	318	16.0	476	23.9
		76	306-212-D	16.6	215	12.9	253	15.2	316	19.0	474	28.5
		89	306-214-D	14.0	211	15.1	249	17.8	311	22.3	461	33.0
102	306-216-D	12.7	220	17.3	259	20.4	324	25.5	457	36.0		
305	306-248-D	3.8	199	51.9	234	61.0	293	76.3	426	111.0		
16.0	8.5	25	306-304-D	136.2	579	4.3	681	5.0	851	6.3	1158	8.5
		32	306-305-D	99.1	539	5.4	634	6.4	792	8.0	1090	11.0
		38	306-306-D	82.8	535	6.5	629	7.6	786	9.5	1092	13.2
		44	306-307-D	70.7	529	7.5	622	8.8	777	11.0	1039	14.7
		51	306-308-D	60.5	525	8.7	617	10.2	772	12.8	1071	17.7
		64	306-310-D	48.1	523	10.9	615	12.8	769	16.0	1053	21.9
		76	306-312-D	39.9	515	12.9	606	15.2	757	19.0	1108	27.8
		89	306-314-D	34.2	518	15.1	609	17.8	762	22.3	1068	31.2
		102	306-316-D	29.5	511	17.3	601	20.4	751	25.5	1116	37.9
		114	306-318-D	26.4	512	19.4	602	22.8	752	28.5	1175	44.5
305	306-348-D	9.8	508	51.9	597	61.0	746	76.3	1106	113.0		
20.0	10.0	25	306-404-D	326.5	1345	4.3	1583	5.0	1978	6.3	2253	6.9
		32	306-405-D	244.9	1291	5.4	1518	6.4	1898	8.0	2302	9.4
		38	306-406-D	199.2	1247	6.5	1467	7.6	1834	9.5	2390	12.0
		44	306-407-D	170.3	1202	7.5	1415	8.8	1768	11.0	2299	13.5
		51	306-408-D	146.9	1202	8.7	1414	10.2	1768	12.8	2380	16.2
		64	306-410-D	114.7	1177	10.9	1385	12.8	1731	16.0	2431	21.2
		76	306-412-D	94.0	1147	12.9	1349	15.2	1686	19.0	2322	24.7
		89	306-414-D	78.4	1119	15.1	1316	17.8	1645	22.3	2258	28.8
		102	306-416-D	68.1	1115	17.3	1312	20.4	1640	25.5	2371	34.8
		115	306-418-D	60.3	1112	19.6	1308	23.0	1635	28.8	2351	39.0
		127	306-420-D	54.0	1101	21.6	1295	25.4	1619	31.8	2324	43.0
		139	306-422-D	48.5	1081	23.6	1272	27.8	1589	34.8	2197	45.3
		152	306-424-D	44.4	1082	25.8	1273	30.4	1591	38.0	2238	50.4
305	306-448-D	22.0	1075	51.9	1265	61.0	1581	76.3	2266	103.0		
25.0	12.5	25	306-504-D	459.0	1951	4.3	2295	5.0	2869	6.3	3351	7.3
		32	306-505-D	348.2	1894	5.4	2229	6.4	2786	8.0	3726	10.7
		38	306-506-D	277.2	1790	6.5	2106	7.6	2633	9.5	3326	12.0
		44	306-507-D	236.2	1767	7.5	2078	8.8	2598	11.0	3401	14.4
		51	306-508-D	196.8	1706	8.7	2008	10.2	2509	12.8	3425	17.4
		64	306-510-D	155.2	1689	10.9	1987	12.8	2483	16.0	3321	21.4
		76	306-512-D	129.3	1671	12.9	1966	15.2	2457	19.0	3479	26.9
		89	306-514-D	108.7	1644	15.1	1934	17.8	2417	22.3	3357	30.9
		102	306-516-D	95.3	1653	17.3	1944	20.4	2430	25.5	3498	36.7
		115	306-518-D	84.9	1659	19.6	1952	23.0	2440	28.8	3421	40.3
		127	306-520-D	76.3	1647	21.6	1938	25.4	2423	31.8	3441	45.1
		139	306-522-D	69.3	1637	23.6	1926	27.8	2408	34.8	3298	47.6
		152	306-524-D	63.5	1640	25.8	1929	30.4	2411	38.0	3395	53.5
		178	306-528-D	54.5	1650	30.3	1942	35.6	2427	44.5	3485	63.9
		203	306-532-D	47.7	1644	34.5	1935	40.6	2418	50.8	3345	70.2
305	306-548-D	31.5	1634	51.9	1922	61.0	2403	76.3	3466	110.0		

ISO



ISO 10243 SERIES

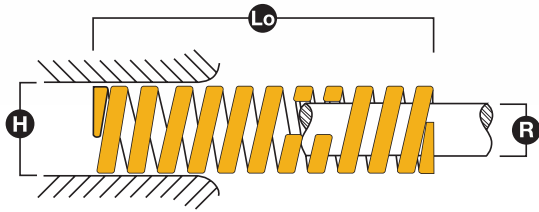

H	R	Lo	Part No.	P/f	L ₁ 17%		L ₂ 20%		L ₃ 25%		L ₄ ⚠			
					N	D	N	D	N	D	N	D		
32.0	16.0	38	306-606-D	478.3	3090	6.5	3635	7.6	4544	9.5	5453	11.4		
		44	306-607-D	420.0	3142	7.5	3696	8.8	4620	11.0	5754	13.7		
		51	306-608-D	351.4	3047	8.7	3584	10.2	4481	12.8	5482	15.6		
		64	306-610-D	273.3	2974	10.9	3499	12.8	4373	16.0	5467	20.0		
		76	306-612-D	226.6	2927	12.9	3444	15.2	4305	19.0	5529	24.4		
		89	306-614-D	193.5	2927	15.1	3444	17.8	4305	22.3	5746	29.7		
		102	306-616-D	162.5	2817	17.3	3314	20.4	4142	25.5	5702	35.1		
		115	306-618-D	144.7	2829	19.6	3328	23.0	4160	28.8	5643	39.0		
		127	306-620-D	132.5	2860	21.6	3364	25.4	4206	31.8	5669	42.8		
		139	306-622-D	118.8	2806	23.6	3302	27.8	4127	34.8	5772	48.6		
		152	306-624-D	109.0	2816	25.8	3313	30.4	4142	38.0	5711	52.4		
		178	306-628-D	91.8	2779	30.3	3270	35.6	4087	44.5	5593	60.9		
		203	306-632-D	80.5	2777	34.5	3267	40.6	4084	50.8	5569	69.2		
		254	306-640-D	64.3	2774	43.2	3264	50.8	4080	63.5	5660	88.1		
305	306-648-D	53.4	2768	51.9	3257	61.0	4071	76.3	5553	104.0				
40.0	20.0	51	306-708-D	588.7	5104	8.7	6004	10.2	7505	12.8	8830	15.0		
		64	306-710-D	452.8	4927	10.9	5796	12.8	7245	16.0	8830	19.5		
		76	306-712-D	373.8	4829	12.9	5681	15.2	7101	19.0	8708	23.3		
		89	306-714-D	314.0	4750	15.1	5588	17.8	6985	22.3	8382	26.7		
		102	306-716-D	273.8	4748	17.3	5585	20.4	6982	25.5	9254	33.8		
		115	306-718-D	242.8	4746	19.6	5583	23.0	6979	28.8	8788	36.2		
		127	306-720-D	218.0	4707	21.6	5538	25.4	6922	31.8	8873	40.7		
		139	306-722-D	196.2	4637	23.6	5455	27.8	6819	34.8	8732	44.5		
		152	306-724-D	179.7	4644	25.8	5464	30.4	6830	38.0	8915	49.6		
		178	306-732-D	151.9	4597	30.3	5408	35.6	6760	44.5	9099	59.9		
		203	306-740-D	132.7	4578	34.5	5386	40.6	6732	50.8	8901	67.1		
		254	306-742-D	105.6	4559	43.2	5364	50.8	6705	63.5	9112	86.3		
		305	306-748-D	87.9	4556	51.9	5359	61.0	6699	76.3	9137	104.0		
		50.0	25.0	64	306-810-D	671.4	7305	10.9	8594	12.8	10742	16.0	14435	21.5
76	306-812-D			537.1	6940	12.9	8164	15.2	10205	19.0	13428	25.0		
89	306-814-D			451.2	6826	15.1	8031	17.8	10039	22.3	13445	29.8		
102	306-816-D			389.0	6744	17.3	7935	20.4	9918	25.5	13497	34.7		
115	306-818-D			341.8	6682	19.6	7861	23.0	9827	28.8	13535	39.6		
127	306-820-D			304.9	6582	21.6	7743	25.4	9679	31.8	13230	43.4		
139	306-822-D			275.1	6501	23.6	7648	27.8	9560	34.8	13013	47.3		
152	306-824-D			250.7	6477	25.8	7620	30.4	9525	38.0	13059	52.1		
178	306-832-D			208.9	6321	30.3	7436	35.6	9295	44.5	12763	61.1		
203	306-840-D			184.9	6381	34.5	7507	40.6	9384	50.8	13055	70.6		
254	306-842-D			146.5	6325	43.2	7442	50.8	9302	63.5	13038	89.0		
305	306-848-D			120.0	6221	51.9	7319	61.0	9149	76.3	12647	105.4		
63.0	38.0			76	306-912-D	952	12300	12.9	14470	15.2	-	-	16374	17.2
				89	306-914-D	819	12391	15.1	14578	17.8	-	-	17265	21.1
		102	306-916-D	700	12138	17.3	14280	20.4	-	-	21490	30.7		
		114	306-918-D	620	12016	19.4	14136	22.8	-	-	21638	34.9		
		127	306-920-D	565	12198	21.6	14351	25.4	-	-	21470	38.0		
		152	306-924-D	458	11835	25.8	13923	30.4	-	-	21618	47.2		
		178	306-928-D	384	11620	30.3	13670	35.6	-	-	21427	55.8		
		203	306-932-D	337	11630	34.5	13682	40.6	-	-	21838	64.8		
		254	306-940-D	263	11356	43.2	13360	50.8	-	-	22802	86.7		
		305	306-948-D	218	11303	51.9	13298	61.0	-	-	23108	106.0		



ISO 10243 SERIES



SUPER HEAVY DUTY ISO COLOUR CODED **SILVER**

CHARGE SUPER FORTE NORME ISO COULEUR **ARGENT**

CARGA SUPER FUERTES PLATA CÓDIGO COLOR SEGÚN ISO

SUPER SCHWERE BEANSPRUCHUNG ISO FARBUNTERLEGTES **SILBER**

CARGO SUPER PESANTE CODICE CROMATICO ISO **ARGENTO**

CARGA SUPER PESADA COR PRATA (ISO)

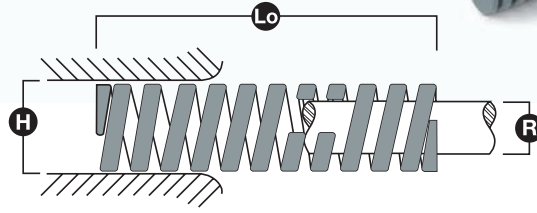

H	R	Lo	Part No.	P/f	L ₁ 10%		L ₂ 13.5%		L ₃ 15%		L ₄ ⚠	
					N	D	N	D	N	D	N	D
25.0	12.5	64	307-510-D	644.0	4122	6.4	5564	8.6	6182	9.6	8501	13.2
		76	307-512-D	556.0	4226	7.6	5705	10.3	6338	11.4	8952	16.1
		89	307-514-D	462.0	4112	8.9	5551	12.0	6168	13.4	9240	20.0
		102	307-516-D	390.0	3978	10.2	5370	13.8	5967	15.3	9048	23.2
		115	307-518-D	360.0	4140	11.5	5589	15.5	6210	17.3	9468	26.3
		127	307-520-D	326.0	4140	12.7	5589	17.1	6210	19.1	9258	28.4
		152	307-524-D	255.0	3876	15.2	5233	20.5	5814	22.8	8696	34.1
		178	307-528-D	230.0	4094	17.8	5527	24.0	6141	26.7	8993	39.1
		203	307-532-D	202.0	4101	20.3	5536	27.4	6151	30.5	9151	45.3
		305	307-548-D	136.0	4148	30.5	5600	41.2	6222	45.8	8582	63.1
32.0	16.0	64	307-610-D	1077.0	6893	6.4	9305	8.6	10339	9.6	14216	13.2
		76	307-612-D	874.0	6642	7.6	8967	10.3	9964	11.4	14071	16.1
		89	307-614-D	721.0	6417	8.9	8663	12.0	9625	13.4	14564	20.2
		102	307-616-D	620.0	6324	10.2	8537	13.8	9486	15.3	14322	23.1
		115	307-618-D	560.0	6440	11.5	8694	15.5	9660	17.3	14784	26.4
		127	307-620-D	496.0	6299	12.7	8504	17.1	9449	19.1	14235	28.7
		152	307-624-D	408.0	6202	15.2	8372	20.5	9302	22.8	13872	34.0
		178	307-628-D	353.0	6283	17.8	8483	24.0	9425	26.7	13838	39.2
		203	307-632-D	304.0	6171	20.3	8331	27.4	9257	30.5	13710	45.1
		254	307-640-D	243.0	6172	25.4	8332	34.3	9258	38.1	15163	62.4
		305	307-648-D	196.0	5978	30.5	8070	41.2	8967	45.8	14720	75.1
40.0	20.0	89	307-714-D	880.0	7832	8.9	10573	12.0	11748	13.4	17776	20.2
		102	307-716-D	762.0	7772	10.2	10493	13.8	11659	15.3	17907	23.5
		115	307-718-D	679.0	7809	11.5	10541	15.5	11713	17.3	17858	26.3
		127	307-720-D	622.0	7899	12.7	10664	17.1	11849	19.1	17540	28.2
		152	307-724-D	509.0	7737	15.2	10445	20.5	11605	22.8	18375	36.1
		178	307-728-D	429.0	7636	17.8	10309	24.0	11454	26.7	18704	43.6
		203	307-732-D	374.0	7592	20.3	10249	27.4	11388	30.5	18588	49.7
		254	307-740-D	296.0	7518	25.4	10150	34.3	11278	38.1	18382	62.1
		305	307-748-D	246.0	7503	30.5	10129	41.2	11255	45.8	18622	75.7
50.0	25.0	89	307-814-D	1410.0	12549	8.9	16941	12.0	18824	13.4	26931	19.1
		102	307-816-D	1215.0	12393	10.2	16731	13.8	18590	15.3	27095	22.3
		115	307-818-D	1076.0	12374	11.5	16705	15.5	18561	17.3	27546	25.6
		127	307-820-D	968.0	12294	12.7	16596	17.1	18440	19.1	27201	28.1
		152	307-824-D	806.0	12251	15.2	16539	20.5	18377	22.8	27888	34.6
		178	307-828-D	698.0	12424	17.8	16773	24.0	18637	26.7	28060	40.2
		203	307-832-D	612.0	12424	20.3	16772	27.4	18635	30.5	27601	45.1
		254	307-840-D	472.0	11989	25.4	16185	34.3	17983	38.1	27518	58.3
		305	307-848-D	388.0	11834	30.5	15976	41.2	17751	45.8	27432	70.7



NOTES

A large rectangular area consisting of 25 horizontal grey bars, intended for handwritten notes.

NAMMS SERIES



MEDIUM DUTY NAMMS COLOUR CODED **BLUE**

CHARGE MOYENNE NAMMS COULEUR **BLEUE**

CARGA MEDIA **AZUL** CÓDIGO COLOR SEGÚN NAMMS

MITTLERE BEANSPRUCHUNG NAMMS FARBUNTERLEGTES **BLAU**

CARICO MEDIO CODICE CROMATICO NAMMS **BLU**

CARGA MEDIA COR DA SÉRIE NAMMS **AZUL**

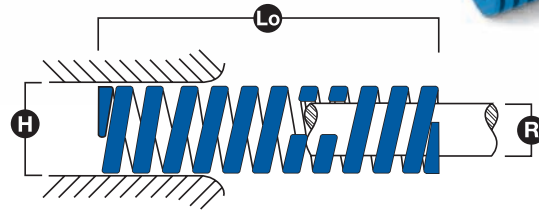

H	R	Lo	Part No.	P/f	L ₁ 25%		L ₂ 35%		L ₃ 40%		L ₄ ⚠
					N	D	N	D	N	D	D
9.53	4.76	25.4	103-104	10.5	67	6.4	93	8.9	107	10.2	12.7
		31.75	103-105	9.5	75	7.9	105	11.1	120	12.7	15.9
		38.1	103-106	7	67	9.5	93	13.3	107	15.2	19.1
		44.45	103-107	6	66	11.1	93	15.6	106	17.8	22.2
		50.8	103-108	4.9	62	12.7	87	17.8	100	20.3	25.4
		63.5	103-110	4.2	67	15.9	93	22.2	107	25.4	31.8
		76.2	103-112	3.7	70	19.1	98	26.7	112	30.5	38.1
		304.8	103-148	1.1	80	76.2	112	106.7	128	121.9	152.4
12.7	7.14	25.4	103-204	19.3	122	6.4	171	8.9	196	10.2	12.7
		31.75	103-205	14.4	114	7.9	160	11.1	182	12.7	15.9
		38.1	103-206	11.9	113	9.5	159	13.3	181	15.2	19.1
		44.45	103-207	10.5	117	11.1	163	15.6	187	17.8	22.2
		50.8	103-208	9.6	122	12.7	171	17.8	196	20.3	25.4
		63.5	103-210	7.9	125	15.9	175	22.2	200	25.4	31.8
		76.2	103-212	6.1	117	19.1	163	26.7	187	30.5	38.1
		88.9	103-214	5.3	117	22.2	163	31.1	187	35.6	44.5
		114.3	103-218	4.4	125	28.6	175	40	200	45.7	57.2
		139.7	103-222	3.7	128	34.9	180	48.9	205	55.9	69.9
		165.1	103-226	2.5	101	41.3	142	57.8	162	66	82.6
		190.5	103-230	2.1	100	47.6	140	66.7	160	76.2	95.3
		304.8	103-248	1.2	93	76.2	131	106.7	149	121.9	152.4
15.88	8.73	25.4	103-304	28.7	182	6.4	255	8.9	292	10.2	12.7
		31.75	103-305	22.4	178	7.9	249	11.1	285	12.7	15.9
		38.1	103-306	18.9	180	9.5	252	13.3	288	15.2	19.1
		44.45	103-307	16.8	187	11.1	262	15.6	299	17.8	22.2
		50.8	103-308	15.4	196	12.7	274	17.8	313	20.3	25.4
		63.5	103-310	10.5	167	15.9	234	22.2	267	25.4	31.8
		76.2	103-312	9.8	187	19.1	262	26.7	299	30.5	38.1
		88.9	103-314	8.4	187	22.2	262	31.1	299	35.6	44.5
		101.6	103-316	7.7	196	25.4	274	35.6	313	40.6	50.8
		304.8	103-348	2.8	214	76.2	299	106.7	342	121.9	152.4
19.05	9.53	25.4	103-404	54.6	347	6.4	486	8.9	555	10.2	12.7
		31.75	103-405	44.8	356	7.9	498	11.1	569	12.7	15.9
		38.1	103-406	35	334	9.5	467	13.3	534	15.2	19.1
		44.45	103-407	30.8	342	11.1	479	15.6	548	17.8	22.2
		50.8	103-408	25.2	320	12.7	448	17.8	512	20.3	25.4
		63.5	103-410	21	334	15.9	467	22.2	534	25.4	31.8
		76.2	103-412	16.8	320	19.1	448	26.7	512	30.5	38.1
		88.9	103-414	14	311	22.2	436	31.1	498	35.6	44.5
		101.6	103-416	12.6	320	25.4	448	35.6	512	40.6	50.8
		114.3	103-418	11.2	320	28.6	448	40	512	45.7	57.2
		127	103-420	10.5	334	31.8	467	44.5	534	50.8	63.5
		139.7	103-422	9.6	336	34.9	471	48.9	538	55.9	69.9
		152.4	103-424	8.8	334	38.1	467	53.3	534	61	76.2
		165.1	103-426	7.9	325	41.3	455	57.8	520	66	82.6
		190.5	103-430	6.7	317	47.6	444	66.7	507	76.2	95.3
		304.8	103-448	4.2	320	76.2	448	106.7	512	121.9	152.4

NAMMS



NAMMS SERIES

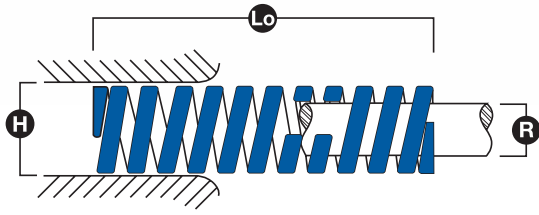

H	R	Lo	Part No.	P/f	L ₁ 25%		L ₂ 35%		L ₃ 40%		L ₄
					N	D	N	D	N	D	D
25.4	12.7	25.4	103-504	96.3	612	6.4	856	8.9	979	10.2	12.7
		31.75	103-505	78.8	626	7.9	876	11.1	1001	12.7	15.9
		38.1	103-506	61.3	584	9.5	817	13.3	934	15.2	19.1
		44.45	103-507	52.5	584	11.1	817	15.6	934	17.8	22.2
		50.8	103-508	45.5	578	12.7	810	17.8	925	20.3	25.4
		63.5	103-510	35	556	15.9	778	22.2	890	25.4	31.8
		76.2	103-512	28.9	550	19.1	771	26.7	881	30.5	38.1
		88.9	103-514	26.3	584	22.2	817	31.1	934	35.6	44.5
		101.6	103-516	21	534	25.4	747	35.6	854	40.6	50.8
		114.3	103-518	18.2	520	28.6	729	40	833	45.7	57.2
		127	103-520	16.8	534	31.8	747	44.5	854	50.8	63.5
		139.7	103-522	15.4	538	34.9	753	48.9	861	55.9	69.9
		152.4	103-524	14	534	38.1	747	53.3	854	61	76.2
		177.8	103-528	12.6	560	44.5	785	62.2	897	71.1	88.9
203.2	103-532	10.5	534	50.8	747	71.1	854	81.3	101.6		
304.8	103-548	7	534	76.2	747	106.7	854	121.9	152.4		
31.75	15.88	38.1	103-606	86.9	827	9.5	1158	13.3	1324	15.2	19.1
		44.45	103-607	74.3	825	11.1	1155	15.6	1320	17.8	22.2
		50.8	103-608	61.6	783	12.7	1096	17.8	1253	20.3	25.4
		63.5	103-610	50.4	801	15.9	1121	22.2	1281	25.4	31.8
		76.2	103-612	42	801	19.1	1121	26.7	1281	30.5	38.1
		88.9	103-614	35	778	22.2	1090	31.1	1245	35.6	44.5
		101.6	103-616	30.8	783	25.4	1096	35.6	1253	40.6	50.8
		114.3	103-618	28	801	28.6	1121	40	1281	45.7	57.2
		127	103-620	23.8	756	31.8	1059	44.5	1210	50.8	63.5
		139.7	103-622	22.4	783	34.9	1096	48.9	1253	55.9	69.9
		152.4	103-624	21	801	38.1	1121	53.3	1281	61	76.2
		177.8	103-628	18.2	810	44.5	1133	62.2	1295	71.1	88.9
		203.2	103-632	15.4	783	50.8	1096	71.1	1253	81.3	101.6
		254	103-640	12.6	801	63.5	1121	88.9	1281	101.6	127
304.8	103-648	10.5	801	76.2	1121	106.7	1281	121.9	152.4		
38.1	19.05	50.8	103-708	92.8	1179	12.7	1650	17.8	1886	20.3	25.4
		63.5	103-710	78.8	1251	15.9	1751	22.2	2002	25.4	31.8
		76.2	103-712	63	1201	19.1	1681	26.7	1922	30.5	38.1
		88.9	103-714	52.5	1168	22.2	1635	31.1	1868	35.6	44.5
		101.6	103-716	47.3	1201	25.4	1681	35.6	1922	40.6	50.8
		114.3	103-718	40.3	1151	28.6	1611	40	1841	45.7	57.2
		127	103-720	36.8	1168	31.8	1635	44.5	1868	50.8	63.5
		139.7	103-722	32.4	1131	34.9	1584	48.9	1810	55.9	69.9
		152.4	103-724	29.8	1134	38.1	1588	53.3	1815	61	76.2
		177.8	103-728	25.4	1129	44.5	1580	62.2	1806	71.1	88.9
		203.2	103-732	22.4	1139	50.8	1594	71.1	1822	81.3	101.6
		254	103-740	17.5	1112	63.5	1557	88.9	1779	101.6	127
		304.8	103-748	14	1068	76.2	1495	106.7	1708	121.9	152.4
		50.8	25.4	63.5	103-810	175.1	2780	15.9	3892	22.2	4448
76.2	103-812			145.3	2769	19.1	3876	26.7	4430	30.5	38.1
88.9	103-814			113.5	2522	22.2	3531	31.1	4035	35.6	44.5
101.6	103-816			105.1	2669	25.4	3736	35.6	4270	40.6	50.8
114.3	103-818			92.8	2652	28.6	3713	40	4243	45.7	57.2
127	103-820			82.3	2613	31.8	3658	44.5	4181	50.8	63.5
139.7	103-822			68.6	2397	34.9	3356	48.9	3836	55.9	69.9
152.4	103-824			68.3	2602	38.1	3643	53.3	4163	61	76.2
177.8	103-828			54.6	2429	44.5	3400	62.2	3886	71.1	88.9
203.2	103-832			49.9	2535	50.8	3550	71.1	4057	81.3	101.6
254	103-840			36.4	2313	63.5	3238	88.9	3701	101.6	127
304.8	103-848			30.6	2335	76.2	3269	106.7	3736	121.9	152.4

NAMMS



NAMMS SERIES



MEDIUM HEAVY DUTY NAMMS COLOUR CODED **RED**

CHARGE MI-FORTE NAMMS COULEUR **ROUGE**

CARGA MEDIA FUERTE **ROJO** CÓDIGO COLOR SEGÚN NAMMS

MITTELSCHWERE BEANSPRUCHUNG NAMMS FARBUNTERLEGTES **ROT**

CARICO MEDIO PESANTE CODICE CROMATICO NAMMS **ROSSO**

CARGA PESADA MEDIA COR DA SÉRIE NAMMS **VERMELHO**

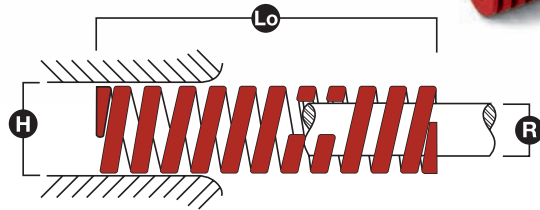

H	R	Lo	Part No.	P/f	L ₁ 20%		L ₂ 25%		L ₃ 30%		L ₄ ⚠
					N	D	N	D	N	D	D
9.53	4.76	25.4	104-104	15.8	80	5.1	100	6.4	120	7.6	9.4
		31.75	104-105	12.8	81	6.4	101	7.9	122	9.5	11.7
		38.1	104-106	11.7	89	7.6	112	9.5	134	11.4	14.1
		44.45	104-107	10.2	90	8.9	113	11.1	135	13.3	16.4
		50.8	104-108	8.8	89	10.2	111	12.7	133	15.2	18.8
		63.5	104-110	7.4	93	12.7	117	15.9	140	19.1	23.5
		76.2	104-112	5.3	80	15.2	100	19.1	120	22.9	28.2
		304.8	104-148	1.6	96	61	120	76.2	144	91.4	112.8
12.7	7.14	25.4	104-204	29.4	149	5.1	187	6.4	224	7.6	9.4
		31.75	104-205	22.8	145	6.4	181	7.9	217	9.5	11.7
		38.1	104-206	16.6	127	7.6	158	9.5	190	11.4	14.1
		44.45	104-207	14.9	132	8.9	165	11.1	198	13.3	16.4
		50.8	104-208	13.1	133	10.2	167	12.7	200	15.2	18.8
		63.5	104-210	10.5	133	12.7	167	15.9	200	19.1	23.5
		76.2	104-212	10	152	15.2	190	19.1	228	22.9	28.2
		88.9	104-214	7	125	17.8	156	22.2	187	26.7	32.9
		304.8	104-248	2.1	128	61	160	76.2	192	91.4	112.8
15.88	8.73	25.4	104-304	52.5	267	5.1	334	6.4	400	7.6	9.4
		31.75	104-305	37.7	239	6.4	299	7.9	359	9.5	11.7
		38.1	104-306	33.3	254	7.6	317	9.5	380	11.4	14.1
		44.45	104-307	29.4	262	8.9	327	11.1	392	13.3	16.4
		50.8	104-308	25.9	263	10.2	329	12.7	395	15.2	18.8
		63.5	104-310	20.1	256	12.7	320	15.9	384	19.1	23.5
		76.2	104-312	17.5	267	15.2	334	19.1	400	22.9	28.2
		88.9	104-314	14.9	265	17.8	331	22.2	397	26.7	32.9
		101.6	104-316	13.3	270	20.3	338	25.4	406	30.5	37.6
		304.8	104-348	4.7	288	61	360	76.2	432	91.4	112.8
19.05	9.53	25.4	104-404	87.6	445	5.1	556	6.4	667	7.6	9.4
		31.75	104-405	66.5	423	6.4	528	7.9	634	9.5	11.7
		38.1	104-406	56	427	7.6	534	9.5	641	11.4	14.1
		44.45	104-407	50.4	448	8.9	560	11.1	673	13.3	16.4
		50.8	104-408	43.4	441	10.2	552	12.7	662	15.2	18.8
		63.5	104-410	33.6	427	12.7	534	15.9	641	19.1	23.5
		76.2	104-412	25.2	384	15.2	480	19.1	576	22.9	28.2
		88.9	104-414	22.4	399	17.8	498	22.2	598	26.7	32.9
		101.6	104-416	21	427	20.3	534	25.4	641	30.5	37.6
		114.3	104-418	19.6	448	22.9	560	28.6	673	34.3	42.3
		127	104-420	15.8	400	25.4	500	31.8	600	38.1	47
		139.7	104-422	14	391	27.9	489	34.9	587	41.9	51.7
		152.4	104-424	13.1	400	30.5	500	38.1	600	45.7	56.4
				304.8	104-448	6.3	384	61	480	76.2	576

NAMMS



NAMMS SERIES

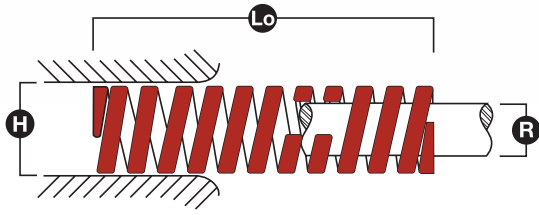

H	R	Lo	Part No.	P/f	L ₁ 20%		L ₂ 25%		L ₃ 30%		L ₄
					N	D	N	D	N	D	D
25.4	12.7	25.4	104-504	133.1	676	5.1	845	6.4	1014	7.6	9.4
		31.75	104-505	109.3	694	6.4	867	7.9	1041	9.5	11.7
		38.1	104-506	86.9	662	7.6	827	9.5	993	11.4	14.1
		44.45	104-507	77.1	685	8.9	856	11.1	1027	13.3	16.4
		50.8	104-508	70	712	10.2	890	12.7	1068	15.2	18.8
		63.5	104-510	54.3	689	12.7	862	15.9	1034	19.1	23.5
		76.2	104-512	43.8	667	15.2	834	19.1	1001	22.9	28.2
		88.9	104-514	37.8	673	17.8	841	22.2	1009	26.7	32.9
		101.6	104-516	32.2	655	20.3	818	25.4	982	30.5	37.6
		114.3	104-518	29.8	681	22.9	851	28.6	1021	34.3	42.3
		127	104-520	25.2	641	25.4	801	31.8	961	38.1	47
		139.7	104-522	22.4	626	27.9	783	34.9	939	41.9	51.7
		152.4	104-524	21	641	30.5	801	38.1	961	45.7	56.4
		177.8	104-528	17.5	623	35.6	778	44.5	934	53.3	65.8
203.2	104-532	15.4	626	40.6	783	50.8	939	61	75.2		
304.8	104-548	10.9	662	61	827	76.2	993	91.4	112.8		
31.75	15.88	38.1	104-606	200.3	1527	7.6	1908	9.5	2290	11.4	14.1
		44.45	104-607	176.5	1569	8.9	1962	11.1	2354	13.3	16.4
		50.8	104-608	151.3	1537	10.2	1922	12.7	2306	15.2	18.8
		63.5	104-610	109.3	1388	12.7	1735	15.9	2082	19.1	23.5
		76.2	104-612	89.7	1366	15.2	1708	19.1	2050	22.9	28.2
		88.9	104-614	77.1	1370	17.8	1712	22.2	2055	26.7	32.9
		101.6	104-616	64.4	1309	20.3	1637	25.4	1964	30.5	37.6
		114.3	104-618	56	1281	22.9	1601	28.6	1922	34.3	42.3
		127	104-620	50.8	1290	25.4	1612	31.8	1935	38.1	47
		139.7	104-622	46.2	1292	27.9	1615	34.9	1938	41.9	51.7
		152.4	104-624	43.8	1334	30.5	1668	38.1	2002	45.7	56.4
		177.8	104-628	35	1245	35.6	1557	44.5	1868	53.3	65.8
		203.2	104-632	32.2	1309	40.6	1637	50.8	1964	61	75.2
		254	104-640	25.4	1290	50.8	1612	63.5	1935	76.2	94
304.8	104-648	21.7	1324	61	1655	76.2	1986	91.4	112.8		
38.1	19.05	50.8	104-708	189.1	1922	10.2	2402	12.7	2882	15.2	18.8
		63.5	104-710	149.9	1904	12.7	2380	15.9	2856	19.1	23.5
		76.2	104-712	109.3	1665	15.2	2082	19.1	2498	22.9	28.2
		88.9	104-714	92.5	1644	17.8	2055	22.2	2466	26.7	32.9
		101.6	104-716	84.1	1708	20.3	2135	25.4	2562	30.5	37.6
		114.3	104-718	75.7	1729	22.9	2162	28.6	2594	34.3	42.3
		127	104-720	64.4	1637	25.4	2046	31.8	2455	38.1	47
		139.7	104-722	60.2	1683	27.9	2104	34.9	2525	41.9	51.7
		152.4	104-724	53.2	1623	30.5	2028	38.1	2434	45.7	56.4
		177.8	104-728	46.2	1644	35.6	2055	44.5	2466	53.3	65.8
		203.2	104-732	38.5	1566	40.6	1957	50.8	2349	61	75.2
		254	104-740	30.8	1566	50.8	1957	63.5	2349	76.2	94
		304.8	104-748	25.2	1537	61	1922	76.2	2306	91.4	112.8
		50.8	25.4	63.5	104-810	207.3	2633	12.7	3292	15.9	3950
76.2	104-812			168.1	2562	15.2	3203	19.1	3843	22.9	28.2
88.9	104-814			140.1	2491	17.8	3114	22.2	3736	26.7	32.9
101.6	104-816			116.3	2363	20.3	2953	25.4	3544	30.5	37.6
114.3	104-818			105.1	2402	22.9	3002	28.6	3603	34.3	42.3
127	104-820			98.1	2491	25.4	3114	31.8	3736	38.1	47
139.7	104-822			88.3	2466	27.9	3082	34.9	3699	41.9	51.7
152.4	104-824			82.7	2519	30.5	3149	38.1	3779	45.7	56.4
177.8	104-828			70	2491	35.6	3114	44.5	3736	53.3	65.8
203.2	104-832			61.6	2505	40.6	3131	50.8	3758	61	75.2
254	104-840			45.5	2313	50.8	2891	63.5	3469	76.2	94
304.8	104-848			39.2	2391	61	2989	76.2	3587	91.4	112.8

NAMMS



NAMMS SERIES



HEAVY DUTY NAMMS COLOUR CODED **GOLD**

CHARGE FORTE NAMMS COULEUR **OR**

CARGA FUERTE **ORO** CÓDIGO COLOR SEGÚN NAMMS

SCHWERE BEANSPRUCHUNG NAMMS FARBUNTERLEGTES **GOLD**

CARICO PESANTE CODICE CROMATICO NAMMS **ORO**

CARGA PESADA COR DA SÉRIE NAMMS **DOURADO**

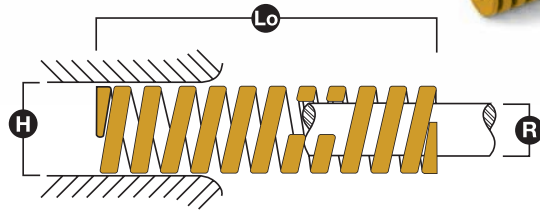

H	R	Lo	Part No.	P/f	L ₁ 15%		L ₂ 20%		L ₃ 25%		L ₄ ⚠
					N	D	N	D	N	D	D
9.53	4.76	25.4	105-104	19.3	73	3.8	98	5.1	122	6.4	7.6
		31.75	105-105	17.2	82	4.8	109	6.4	136	7.9	9.5
		38.1	105-106	14	80	5.7	107	7.6	133	9.5	11.4
		44.45	105-107	14.7	98	6.7	131	8.9	163	11.1	13.3
		50.8	105-108	12.6	96	7.6	128	10.2	160	12.7	15.2
		63.5	105-110	9.6	92	9.5	122	12.7	153	15.9	19.1
		76.2	105-112	7.4	84	11.4	112	15.2	140	19.1	22.9
		304.8	105-148	2.1	96	45.7	128	61	160	76.2	91.4
12.7	7.14	25.4	105-204	41.3	157	3.8	210	5.1	262	6.4	7.6
		31.75	105-205	32.6	155	4.8	207	6.4	259	7.9	9.5
		38.1	105-206	27.1	155	5.7	207	7.6	259	9.5	11.4
		44.45	105-207	24.2	161	6.7	215	8.9	269	11.1	13.3
		50.8	105-208	19.3	147	7.6	196	10.2	245	12.7	15.2
		63.5	105-210	14.7	140	9.5	187	12.7	234	15.9	19.1
		76.2	105-212	13	148	11.4	197	15.2	247	19.1	22.9
		88.9	105-214	10.5	140	13.3	187	17.8	234	22.2	26.7
		304.8	105-248	2.8	128	45.7	171	61	214	76.2	91.4
15.88	8.73	25.4	105-304	74.3	283	3.8	377	5.1	471	6.4	7.6
		31.75	105-305	51.8	247	4.8	329	6.4	411	7.9	9.5
		38.1	105-306	47.6	272	5.7	363	7.6	454	9.5	11.4
		44.45	105-307	42	280	6.7	374	8.9	467	11.1	13.3
		50.8	105-308	36.4	278	7.6	370	10.2	463	12.7	15.2
		63.5	105-310	29.8	284	9.5	378	12.7	473	15.9	19.1
		76.2	105-312	25.2	288	11.4	384	15.2	480	19.1	22.9
		88.9	105-314	21.4	285	13.3	380	17.8	475	22.2	26.7
		101.6	105-316	18.9	288	15.2	384	20.3	480	25.4	30.5
		304.8	105-348	5.3	240	45.7	320	61	400	76.2	91.4
19.05	9.53	25.4	105-404	189.1	721	3.8	961	5.1	1201	6.4	7.6
		31.75	105-405	154.1	734	4.8	979	6.4	1223	7.9	9.5
		38.1	105-406	114.9	657	5.7	875	7.6	1094	9.5	11.4
		44.45	105-407	105.1	701	6.7	934	8.9	1168	11.1	13.3
		50.8	105-408	86.9	662	7.6	882	10.2	1103	12.7	15.2
		63.5	105-410	70	667	9.5	890	12.7	1112	15.9	19.1
		76.2	105-412	59.5	681	11.4	907	15.2	1134	19.1	22.9
		88.9	105-414	49	654	13.3	872	17.8	1090	22.2	26.7
		101.6	105-416	43.8	667	15.2	890	20.3	1112	25.4	30.5
		114.3	105-418	38.5	661	17.1	881	22.9	1101	28.6	34.3
		127	105-420	34.1	651	19.1	867	25.4	1084	31.8	38.1
		139.7	105-422	29.8	624	21	832	27.9	1040	34.9	41.9
		152.4	105-424	28	641	22.9	854	30.5	1068	38.1	45.7
304.8	105-448	14	641	45.7	854	61	1068	76.2	91.4		

NAMMS



NAMMS SERIES

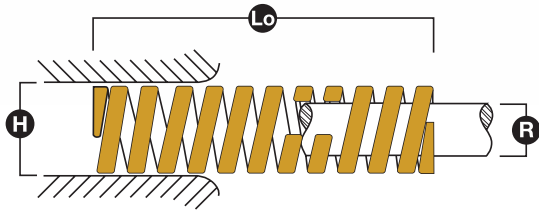

H	R	Lo	Part No.	P/f	L ₁ 15%		L ₂ 20%		L ₃ 25%		L ₄
					N	D	N	D	N	D	D
25.4	12.7	25.4	105-504	364.2	1388	3.8	1850	5.1	2313	6.4	7.6
		31.75	105-505	299.8	1428	4.8	1904	6.4	2380	7.9	9.5
		38.1	105-506	207.3	1185	5.7	1580	7.6	1975	9.5	11.4
		44.45	105-507	182.1	1214	6.7	1619	8.9	2024	11.1	13.3
		50.8	105-508	157.6	1201	7.6	1601	10.2	2002	12.7	15.2
		63.5	105-510	119.1	1134	9.5	1512	12.7	1890	15.9	19.1
		76.2	105-512	95.3	1089	11.4	1452	15.2	1815	19.1	22.9
		88.9	105-514	79.9	1065	13.3	1420	17.8	1775	22.2	26.7
		101.6	105-516	70	1068	15.2	1423	20.3	1779	25.4	30.5
		114.3	105-518	61.6	1057	17.1	1409	22.9	1761	28.6	34.3
		127	105-520	54.6	1041	19.1	1388	25.4	1735	31.8	38.1
		139.7	105-522	50.4	1057	21	1409	27.9	1761	34.9	41.9
		152.4	105-524	44.8	1025	22.9	1366	30.5	1708	38.1	45.7
		177.8	105-528	39.2	1046	26.7	1395	35.6	1744	44.5	53.3
203.2	105-532	33.6	1025	30.5	1366	40.6	1708	50.8	61		
304.8	105-548	21	961	45.7	1281	61	1601	76.2	91.4		
31.75	15.88	38.1	105-606	371.3	2122	5.7	2829	7.6	3536	9.5	11.4
		44.45	105-607	318	2120	6.7	2827	8.9	3534	11.1	13.3
		50.8	105-608	262	1996	7.6	2662	10.2	3327	12.7	15.2
		63.5	105-610	205.9	1962	9.5	2615	12.7	3269	15.9	19.1
		76.2	105-612	166.7	1906	11.4	2541	15.2	3176	19.1	22.9
		88.9	105-614	131.7	1756	13.3	2341	17.8	2927	22.2	26.7
		101.6	105-616	116.3	1772	15.2	2363	20.3	2953	25.4	30.5
		114.3	105-618	102.3	1753	17.1	2338	22.9	2922	28.6	34.3
		127	105-620	92.8	1768	19.1	2357	25.4	2947	31.8	38.1
		139.7	105-622	82.7	1732	21	2309	27.9	2887	34.9	41.9
		152.4	105-624	74.3	1697	22.9	2263	30.5	2829	38.1	45.7
		177.8	105-628	64.4	1719	26.7	2292	35.6	2865	44.5	53.3
		203.2	105-632	57.4	1751	30.5	2334	40.6	2918	50.8	61
		254	105-640	44.8	1708	38.1	2277	50.8	2847	63.5	76.2
304.8	105-648	36.4	1665	45.7	2220	61	2776	76.2	91.4		
38.1	19.05	50.8	105-708	333.4	2541	7.6	3388	10.2	4234	12.7	15.2
		63.5	105-710	271.4	2585	9.5	3447	12.7	4309	15.9	19.1
		76.2	105-712	227.7	2602	11.4	3469	15.2	4337	19.1	22.9
		88.9	105-714	186.3	2485	13.3	3313	17.8	4141	22.2	26.7
		101.6	105-716	159.7	2434	15.2	3245	20.3	4057	25.4	30.5
		114.3	105-718	137.3	2354	17.1	3139	22.9	3923	28.6	34.3
		127	105-720	124.7	2375	19.1	3167	25.4	3959	31.8	38.1
		139.7	105-722	112.1	2349	21	3131	27.9	3914	34.9	41.9
		152.4	105-724	102.3	2338	22.9	3117	30.5	3896	38.1	45.7
		177.8	105-728	86.9	2317	26.7	3089	35.6	3861	44.5	53.3
		203.2	105-732	75.7	2306	30.5	3074	40.6	3843	50.8	61
		254	105-740	60.2	2295	38.1	3060	50.8	3825	63.5	76.2
		304.8	105-748	50.4	2306	45.7	3074	61	3843	76.2	91.4
		50.8	25.4	63.5	105-810	455.3	4337	9.5	5782	12.7	7228
76.2	105-812			350.2	4003	11.4	5338	15.2	6672	19.1	22.9
88.9	105-814			297.7	3970	13.3	5293	17.8	6616	22.2	26.7
101.6	105-816			262.7	4003	15.2	5338	20.3	6672	25.4	30.5
114.3	105-818			210.1	3603	17.1	4804	22.9	6005	28.6	34.3
127	105-820			192.6	3670	19.1	4893	25.4	6116	31.8	38.1
139.7	105-822			175.1	3670	21	4893	27.9	6116	34.9	41.9
152.4	105-824			164.6	3763	22.9	5017	30.5	6272	38.1	45.7
177.8	105-828			143.6	3830	26.7	5106	35.6	6383	44.5	53.3
203.2	105-832			127.8	3896	30.5	5195	40.6	6494	50.8	61
254	105-840			96.3	3670	38.1	4893	50.8	6116	63.5	76.2
304.8	105-848			73.5	3363	45.7	4484	61	5604	76.2	91.4

NAMMS



NAMMS SERIES



EXTRA HEAVY DUTY NAMMS COLOUR CODED **GREEN**

CHARGE EXTRA-FORTE NAMMS COULEUR **VERTE**

CARGA EXTRA FUERTE **VERDE** CÓDIGO COLOR SEGÚN NAMMS

EXTRA STARKE BEANSPRUCHUNG NAMMS FARBUNTERLEGTES **GRÜN**

CARICO EXTRA PESANTE CODICE CROMATICO NAMMS **VERDE**

CARGA EXTRA PESADA COR DA SÉRIE NAMMS **VERDE**

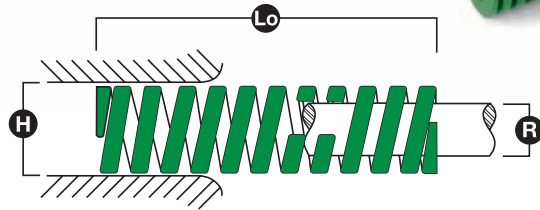

H	R	Lo	Part No.	P/f	L ₁ 15%		L ₂ 17%		L ₃ 20%		L ₄ ⚠
					N	D	N	D	N	D	D
9.53	4.76	25.4	106-104	38.5	147	3.8	166	4.3	196	5.1	6.4
		31.75	106-105	28	133	4.8	151	5.4	178	6.4	7.9
		38.1	106-106	21.9	125	5.7	142	6.5	167	7.6	9.5
		44.45	106-107	20.1	134	6.7	152	7.6	179	8.9	11.1
		50.8	106-108	15.8	120	7.6	136	8.6	160	10.2	12.7
		63.5	106-110	12.3	117	9.5	132	10.8	156	12.7	15.9
		76.2	106-112	11.4	130	11.4	147	13	173	15.2	19.1
		304.8	106-148	2.6	120	45.7	136	51.8	160	61	76.2
12.7	7.14	25.4	106-204	56	214	3.8	242	4.3	285	5.1	6.4
		31.75	106-205	42	200	4.8	227	5.4	267	6.4	7.9
		38.1	106-206	35	200	5.7	227	6.5	267	7.6	9.5
		44.45	106-207	29.8	198	6.7	225	7.6	265	8.9	11.1
		50.8	106-208	24.5	187	7.6	212	8.6	249	10.2	12.7
		63.5	106-210	20.1	192	9.5	217	10.8	256	12.7	15.9
		76.2	106-212	15.8	180	11.4	204	13	240	15.2	19.1
		88.9	106-214	14	187	13.3	212	15.1	249	17.8	22.2
		304.8	106-248	4.4	200	45.7	227	51.8	267	61	76.2
15.88	8.73	25.4	106-304	110.3	420	3.8	476	4.3	560	5.1	6.4
		31.75	106-305	82.3	392	4.8	444	5.4	523	6.4	7.9
		38.1	106-306	66.5	380	5.7	431	6.5	507	7.6	9.5
		44.45	106-307	56	374	6.7	423	7.6	498	8.9	11.1
		50.8	106-308	50.8	387	7.6	439	8.6	516	10.2	12.7
		63.5	106-310	38.5	367	9.5	416	10.8	489	12.7	15.9
		76.2	106-312	33.3	380	11.4	431	13	507	15.2	19.1
		88.9	106-314	28	374	13.3	423	15.1	498	17.8	22.2
		101.6	106-316	23.6	360	15.2	408	17.3	480	20.3	25.4
		304.8	106-348	7.9	360	45.7	408	51.8	480	61	76.2
19.05	9.53	25.4	106-404	245.2	934	3.8	1059	4.3	1245	5.1	6.4
		31.75	106-405	192.6	917	4.8	1040	5.4	1223	6.4	7.9
		38.1	106-406	155.9	891	5.7	1009	6.5	1188	7.6	9.5
		44.45	106-407	131.3	876	6.7	992	7.6	1168	8.9	11.1
		50.8	106-408	119.1	907	7.6	1028	8.6	1210	10.2	12.7
		63.5	106-410	87.6	834	9.5	945	10.8	1112	12.7	15.9
		76.2	106-412	70.9	811	11.4	919	13	1081	15.2	19.1
		88.9	106-414	60.4	806	13.3	913	15.1	1074	17.8	22.2
		101.6	106-416	52.5	801	15.2	907	17.3	1068	20.3	25.4
		114.3	106-418	46.4	796	17.1	902	19.4	1061	22.9	28.6
		127	106-420	41.2	784	19.1	888	21.6	1045	25.4	31.8
		139.7	106-422	37.7	789	21	894	23.7	1052	27.9	34.9
		152.4	106-424	34.1	781	22.9	885	25.9	1041	30.5	38.1
		304.8	106-448	16.6	761	45.7	862	51.8	1014	61	76.2

NAMMS



NAMMS SERIES

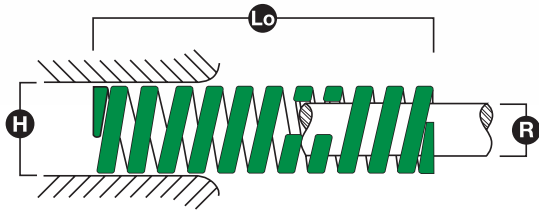

H	R	Lo	Part No.	P/f	L ₁ 15%		L ₂ 17%		L ₃ 20%		L ₄
					N	D	N	D	N	D	D
25.4	12.7	38.1	106-506	280.2	1601	5.7	1815	6.5	2135	7.6	9.5
		50.8	106-508	203.1	1548	7.6	1754	8.6	2064	10.2	12.7
		63.5	106-510	156.9	1495	9.5	1694	10.8	1993	12.7	5.9
		76.2	106-512	128.9	1473	11.4	1670	13	1964	15.2	19.1
		88.9	106-514	109.3	1457	13.3	1651	15.1	1943	17.8	22.2
		101.6	106-516	96.7	1473	15.2	1670	17.3	1964	20.3	25.4
		114.3	106-518	85.5	1465	17.1	1661	19.4	1954	22.9	28.6
		127	106-520	75.7	1441	19.1	1633	21.6	1922	25.4	31.8
		152.4	106-524	63	1441	22.9	1633	25.9	1922	30.5	38.1
304.8	106-548	30.8	1409	45.7	1597	51.8	1879	61	76.2		
31.75	15.88	50.8	106-608	336.2	2562	7.6	2904	8.6	3416	10.2	12.7
		63.5	106-610	252.2	2402	9.5	2722	10.8	3203	12.7	15.9
		76.2	106-612	207.3	2370	11.4	2686	13	3160	15.2	19.1
		88.9	106-614	176.5	2354	13.3	2668	15.1	3139	17.8	22.2
		101.6	106-616	147.1	2242	15.2	2541	17.3	2989	20.3	25.4
		114.3	106-618	137.3	2354	17.1	2668	19.4	3139	22.9	28.6
		127	106-620	119.1	2268	19.1	2571	21.6	3025	25.4	31.8
		152.4	106-624	98.1	2242	22.9	2541	25.9	2989	30.5	38.1
		203.2	106-632	72.8	2220	30.5	2517	34.5	2961	40.6	50.8
254	106-640	58.8	2242	38.1	2541	43.2	2989	50.8	63.5		
304.8	106-648	46.2	2114	45.7	2396	51.8	2818	61	76.2		
38.1	19.05	50.8	106-708	658.4	5017	7.6	5686	8.6	6690	10.2	12.7
		63.5	106-710	515.5	4911	9.5	5565	10.8	6547	12.7	15.9
		76.2	106-712	404.9	4628	11.4	5245	13	6170	15.2	19.1
		88.9	106-714	343.2	4577	13.3	5187	15.1	6103	17.8	22.2
		101.6	106-716	299.8	4569	15.2	5178	17.3	6092	20.3	25.4
		114.3	106-718	259.2	4444	17.1	5036	19.4	5925	22.9	28.6
		127	106-720	238.2	4537	19.1	5142	21.6	6049	25.4	31.8
		152.4	106-724	193.3	4420	22.9	5009	25.9	5893	30.5	38.1
		203.2	106-732	141.5	4313	30.5	4888	34.5	5750	40.6	50.8
254	106-740	117.7	4484	38.1	5081	43.2	5978	50.8	63.5		
304.8	106-748	95.3	4355	45.7	4936	51.8	5807	61	76.2		
50.8	25.4	63.5	106-810	668.3	6365	9.5	7214	10.8	8487	12.7	15.9
		76.2	106-812	546.4	6245	11.4	7078	13	8327	15.2	19.1
		88.9	106-814	445.5	5941	13.3	6733	15.1	7921	17.8	22.2
		101.6	106-816	385.3	5871	15.2	6654	17.3	7828	20.3	25.4
		114.3	106-818	330.6	5669	17.1	6424	19.4	7558	22.9	28.6
		127	106-820	302.6	5765	19.1	6533	21.6	7686	25.4	31.8
		152.4	106-824	248	5669	22.9	6424	25.9	7558	30.5	38.1
		203.2	106-832	175.1	5338	30.5	6049	34.5	7117	40.6	50.8
		254	106-840	147.1	5604	38.1	6352	43.2	7473	50.8	63.5
304.8	106-848	124.7	5701	45.7	6461	51.8	7601	61	76.2		

NAMMS



JIS B 5012 SERIES



EXTRA LIGHT DUTY JIS COLOUR CODED **YELLOW**

CHARGE SUPER LÉGÈRE JIS COULEUR **JAUNE**

CARGA EXTRA LIGERA **AMARILLO** CÓDIGO COLOR SEGÚN JIS

EXTRA LEICHTE BEANSPRUCHUNG JIS FARBUNTERLEGTES **GELB**

CARICO EXTRA PESANTE CODICE CROMATICO JIS **GIALLO**

CARGA EXTRA LEVE COR DA SÉRIE JIS **AMARELO**

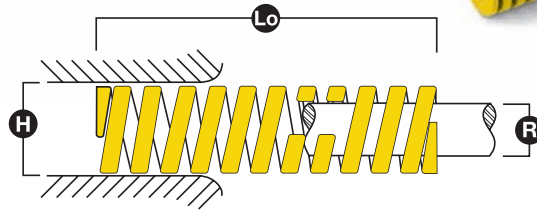

H	R	Lo	Part No.	P/f	L ₁ 40%		L ₂ 45%		L ₃ 50%	
					N	D	N	D	N	D
8	4	10	ASF 8 X 10	1.56	59	4.0	69	4.5	79	5.0
		15	ASF 8 X 15	1.04		6.0		6.8		7.5
		20	ASF 8 X 20	0.78		8.0		9.0		10.0
		25	ASF 8 X 25	0.62		10.0		11.2		12.5
		30	ASF 8 X 30	0.52		12.0		13.5		15.0
		35	ASF 8 X 35	0.44		14.0		15.7		17.5
		40	ASF 8 X 40	0.39		16.0		18.0		20.0
		45	ASF 8 X 45	0.35		18.0		20.2		22.5
		50	ASF 8 X 50	0.31		20.0		22.5		25.0
		55	ASF 8 X 55	0.28		22.0		24.7		27.5
		60	ASF 8 X 60	0.26	24.0	27.0	30.0			
10	5	20	ASF 10 X 20	1.00	79	8.0	88	9.0	98	10.0
		25	ASF 10 X 25	0.80		10.0		11.2		12.5
		30	ASF 10 X 30	0.67		12.0		13.5		15.0
		35	ASF 10 X 35	0.57		14.0		15.7		17.5
		40	ASF 10 X 40	0.50		16.0		18.0		20.0
		45	ASF 10 X 45	0.44		18.0		20.2		22.5
		50	ASF 10 X 50	0.40		20.0		22.5		25.0
		55	ASF 10 X 55	0.36		22.0		24.7		27.5
		60	ASF 10 X 60	0.33		24.0		27.0		30.0
		65	ASF 10 X 65	0.31		26.0		29.2		32.5
		70	ASF 10 X 70	0.29	28.0	31.5	35.0			
		75	ASF 10 X 75	0.27	30.0	33.7	37.5			
		80	ASF 10 X 80	0.25	32.0	36.0	40.0			
12	6	20	ASF 12 X 20	1.40	108	8.0	123	9.0	137	10.0
		25	ASF 12 X 25	1.12		10.0		11.2		12.5
		30	ASF 12 X 30	0.93		12.0		13.5		15.0
		35	ASF 12 X 35	0.80		14.0		15.7		17.5
		40	ASF 12 X 40	0.70		16.0		18.0		20.0
		45	ASF 12 X 45	0.62		18.0		20.2		22.5
		50	ASF 12 X 50	0.56		20.0		22.5		25.0
		55	ASF 12 X 55	0.51		22.0		24.7		27.5
		60	ASF 12 X 60	0.47		24.0		27.0		30.0
		65	ASF 12 X 65	0.43		26.0		29.2		32.5
		70	ASF 12 X 70	0.40	28.0	31.5	35.0			
		75	ASF 12 X 75	0.37	30.0	33.7	37.5			
		80	ASF 12 X 80	0.35	32.0	36.0	40.0			
14	7	25	ASF 14 X 25	1.44	142	10.0	157	11.2	177	12.5
		30	ASF 14 X 30	1.20		12.0		13.5		15.0
		35	ASF 14 X 35	1.03		14.0		15.7		17.5
		40	ASF 14 X 40	0.90		16.0		18.0		20.0
		45	ASF 14 X 45	0.80		18.0		20.2		22.5
		50	ASF 14 X 50	0.72		20.0		22.5		25.0
		55	ASF 14 X 55	0.65		22.0		24.7		27.5
		60	ASF 14 X 60	0.60		24.0		27.0		30.0
		65	ASF 14 X 65	0.55		26.0		29.2		32.5
		70	ASF 14 X 70	0.51		28.0		31.5		35.0
		75	ASF 14 X 75	0.48	30.0	33.7	37.5			
		80	ASF 14 X 80	0.45	32.0	36.0	40.0			
		90	ASF 14 X 90	0.40	36.0	40.5	45.0			

JIS



JIS B 5012 SERIES

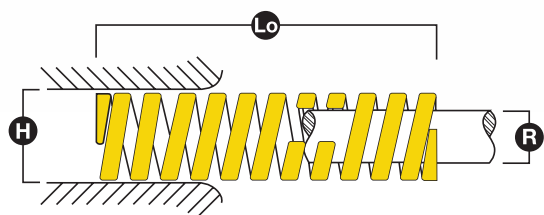

H	R	Lo	Part No.	P/f	L ₁ 40%		L ₂ 45%		L ₃ 50%	
					N	D	N	D	N	D
16	8	25	ASF 16 X 25	1.68	167	10.0	186	11.2	206	12.5
		30	ASF 16 X 30	1.40		12.0		13.5		15.0
		35	ASF 16 X 35	1.20		14.0		15.7		17.5
		40	ASF 16 X 40	1.05		16.0		18.0		20.0
		45	ASF 16 X 45	0.94		18.0		20.2		22.5
		50	ASF 16 X 50	0.84		20.0		22.5		25.0
		55	ASF 16 X 55	0.77		22.0		24.7		27.5
		60	ASF 16 X 60	0.70		24.0		27.0		30.0
		65	ASF 16 X 65	0.65		26.0		29.2		32.5
		70	ASF 16 X 70	0.60		28.0		31.5		35.0
		75	ASF 16 X 75	0.56		30.0		33.7		37.5
		80	ASF 16 X 80	0.53		32.0		36.0		40.0
90	ASF 16 X 90	0.47	36.0	40.5	45.0					
100	ASF 16 X 100	0.42	40.0	45.0	50.0					
18	9	25	ASF 18 X 25	2.08	206	10.0	256	11.2	255	12.5
		30	ASF 18 X 30	1.74		12.0		13.5		15.0
		35	ASF 18 X 35	1.49		14.0		15.7		17.5
		40	ASF 18 X 40	1.30		16.0		18.0		20.0
		45	ASF 18 X 45	1.16		18.0		20.2		22.5
		50	ASF 18 X 50	1.04		20.0		22.5		25.0
		55	ASF 18 X 55	0.95		22.0		24.7		27.5
		60	ASF 18 X 60	0.87		24.0		27.0		30.0
		65	ASF 18 X 65	0.80		26.0		29.2		32.5
		70	ASF 18 X 70	0.74		28.0		31.5		35.0
		75	ASF 18 X 75	0.70		30.0		33.7		37.5
		80	ASF 18 X 80	0.65		32.0		36.0		40.0
90	ASF 18 X 90	0.58	36.0	40.5	45.0					
100	ASF 18 X 100	0.52	40.0	45.0	50.0					
20	11	25	ASF 20 X 25	2.56	255	10.0	284	11.2	314	12.5
		30	ASF 20 X 30	2.13		12.0		13.5		15.0
		35	ASF 20 X 35	1.83		14.0		15.7		17.5
		40	ASF 20 X 40	1.60		16.0		18.0		20.0
		45	ASF 20 X 45	1.42		18.0		20.2		22.5
		50	ASF 20 X 50	1.28		20.0		22.5		25.0
		55	ASF 20 X 55	1.16		22.0		24.7		27.5
		60	ASF 20 X 60	1.07		24.0		27.0		30.0
		65	ASF 20 X 65	0.98		26.0		29.2		32.5
		70	ASF 20 X 70	0.91		28.0		31.5		35.0
		75	ASF 20 X 75	0.85		30.0		33.7		37.5
		80	ASF 20 X 80	0.80		32.0		36.0		40.0
		90	ASF 20 X 90	0.71		36.0		40.5		45.0
		100	ASF 20 X 100	0.64		40.0		45.0		50.0
		125	ASF 20 X 125	0.51		50.0		56.2		62.5
150	ASF 20 X 150	0.43	60.0	67.5	75.0					

JIS B 5012 SERIES



EXTRA LIGHT DUTY JIS COLOUR CODED **YELLOW**

CHARGE SUPER LÉGÈRE JIS COULEUR **JAUNE**

CARGA EXTRA LIGERA **AMARILLO** CÓDIGO COLOR SEGÚN JIS

EXTRA LEICHTE BEANSPRUCHUNG JIS FARBUNTERLEGTES **GELB**

CARICO EXTRA PESANTE CODICE CROMATICO JIS **GIALLO**

CARGA EXTRA LEVE COR DA SÉRIE JIS **AMARELO**

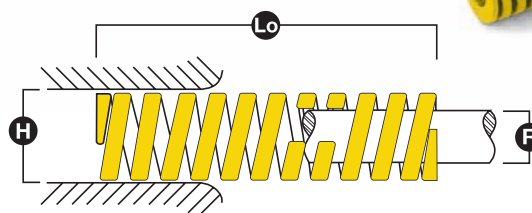

H	R	Lo	Part No.	P/f	L ₁ 32%		L ₂ 36%		L ₃ 40%	
					N	D	N	D	N	D
22	11	25	ASF 22 X 25	3.20	314	10.0	353	11.2	392	12.5
		30	ASF 22 X 30	2.67		12.0		13.5		15.0
		35	ASF 22 X 35	2.29		14.0		15.7		17.5
		40	ASF 22 X 40	2.00		16.0		18.0		20.0
		45	ASF 22 X 45	1.78		18.0		20.2		22.5
		50	ASF 22 X 50	1.60		20.0		22.5		25.0
		55	ASF 22 X 55	1.46		22.0		24.7		27.5
		60	ASF 22 X 60	1.33		24.0		27.0		30.0
		65	ASF 22 X 65	1.23		26.0		29.2		32.5
		70	ASF 22 X 70	1.14		28.0		31.5		35.0
		75	ASF 22 X 75	1.07		30.0		33.7		37.5
		80	ASF 22 X 80	1.00		32.0		36.0		40.0
		90	ASF 22 X 90	0.89		36.0		40.5		45.0
		100	ASF 22 X 100	0.80		40.0		45.0		50.0
		125	ASF 22 X 125	0.64		50.0		56.2		62.5
150	ASF 22 X 150	0.53	60.0	67.5	75.0					
25	13.5	25	ASF 25 X 25	4.00	392	10.0	441	11.2	450	12.5
		30	ASF 25 X 30	3.33		12.0		13.5		15.0
		35	ASF 25 X 35	2.85		14.0		15.7		17.5
		40	ASF 25 X 40	2.50		16.0		18.0		20.0
		45	ASF 25 X 45	2.22		18.0		20.2		22.5
		50	ASF 25 X 50	2.00		20.0		22.5		25.0
		55	ASF 25 X 55	1.82		22.0		24.7		27.5
		60	ASF 25 X 60	1.67		24.0		27.0		30.0
		65	ASF 25 X 65	1.54		26.0		29.2		32.5
		70	ASF 25 X 70	1.43		28.0		31.5		35.0
		75	ASF 25 X 75	1.33		30.0		33.7		37.5
		80	ASF 25 X 80	1.25		32.0		36.0		40.0
		90	ASF 25 X 90	1.11		36.0		40.5		45.0
		100	ASF 25 X 100	1.00		40.0		45.0		50.0
		125	ASF 25 X 125	0.80		50.0		56.2		62.5
150	ASF 25 X 150	0.67	60.0	67.5	75.0					
175	ASF 25 X 175	0.57	70.0	78.7	87.5					
27	13.5	25	ASF 27 X 25	4.80	471	10.0	530	11.2	588	12.5
		30	ASF 27 X 30	4.00		12.0		13.5		15.0
		35	ASF 27 X 35	3.43		14.0		15.7		17.5
		40	ASF 27 X 40	3.00		16.0		18.0		20.0
		45	ASF 27 X 45	2.67		18.0		20.2		22.5
		50	ASF 27 X 50	2.40		20.0		22.5		25.0
		55	ASF 27 X 55	2.18		22.0		24.7		27.5
		60	ASF 27 X 60	2.00		24.0		27.0		30.0
		65	ASF 27 X 65	1.85		26.0		29.2		32.5
		70	ASF 27 X 70	1.71		28.0		31.5		35.0
		75	ASF 27 X 75	1.60		30.0		33.7		37.5
		80	ASF 27 X 80	1.50		32.0		36.0		40.0
		90	ASF 27 X 90	1.33		36.0		40.5		45.0
		100	ASF 27 X 100	1.20		40.0		45.0		50.0
		125	ASF 27 X 125	0.96		50.0		56.2		62.5
150	ASF 27 X 150	0.80	60.0	67.5	75.0					
175	ASF 27 X 175	0.69	70.0	78.7	87.5					

JIS



JIS B 5012 SERIES

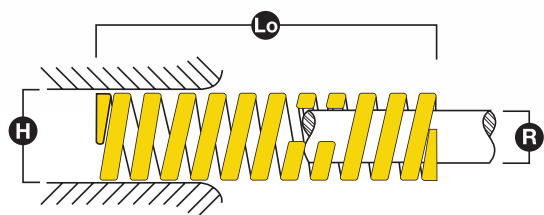

H	R	Lo	Part No.	P/f	L ₁ 32%		L ₂ 36%		L ₃ 40%			
					N	D	N	D	N	D		
30	16	25	ASF 30 X 25	5.80	569	10.0	637	11.2	706	12.5		
		30	ASF 30 X 30	4.80		12.0					13.5	15.0
		35	ASF 30 X 35	4.13		14.0					15.7	17.5
		40	ASF 30 X 40	3.60		16.0					18.0	20.0
		45	ASF 30 X 45	3.21		18.0					20.2	22.5
		50	ASF 30 X 50	2.88		20.0					22.5	25.0
		55	ASF 30 X 55	2.63		22.0					24.7	27.5
		60	ASF 30 X 60	2.40		24.0					27.0	30.0
		65	ASF 30 X 65	2.22		26.0					29.2	32.5
		70	ASF 30 X 70	2.05		28.0					31.5	35.0
		75	ASF 30 X 75	1.93		30.0					33.7	37.5
		80	ASF 30 X 80	1.80		32.0					36.0	40.0
		90	ASF 30 X 90	1.60		36.0					40.5	45.0
		100	ASF 30 X 100	1.44		40.0					45.0	50.0
		125	ASF 30 X 125	1.15		50.0					56.2	62.5
35	19	40	ASF 35 X 40	4.90	765	16.0	963	18.0	961	20.0		
		45	ASF 35 X 45	4.36		18.0					20.2	22.5
		50	ASF 35 X 50	3.92		20.0					22.5	25.0
		55	ASF 35 X 55	3.56		22.0					24.7	27.5
		60	ASF 35 X 60	3.26		24.0					27.0	30.0
		65	ASF 35 X 65	3.02		26.0					29.2	32.5
		70	ASF 35 X 70	2.80		28.0					31.5	35.0
		75	ASF 35 X 75	2.61		30.0					33.7	37.5
		80	ASF 35 X 80	2.45		32.0					36.0	40.0
		90	ASF 35 X 90	2.17		36.0					40.5	45.0
		100	ASF 35 X 100	1.96		40.0					45.0	50.0
		125	ASF 35 X 125	1.57		50.0					56.2	62.5
		150	ASF 35 X 150	1.30		60.0					67.5	75.0
		175	ASF 35 X 175	1.12		70.0					78.7	87.5
		200	ASF 35 X 200	0.98		80.0					90.0	100.0
40	22	40	ASF 40 X 40	6.38	1,000	16.0	1,128	18.0	1,255	20.0		
		50	ASF 40 X 50	5.12		20.0					22.5	25.0
		60	ASF 40 X 60	4.26		24.0					27.0	30.0
		70	ASF 40 X 70	3.65		28.0					31.5	35.0
		80	ASF 40 X 80	3.20		32.0					36.0	40.0
		90	ASF 40 X 90	2.84		36.0					40.5	45.0
		100	ASF 40 X 100	2.56		40.0					45.0	50.0
		125	ASF 40 X 125	2.04		50.0					56.2	62.5
		150	ASF 40 X 150	1.70		60.0					67.5	75.0
		175	ASF 40 X 175	1.46		70.0					78.7	87.5
		200	ASF 40 X 200	1.28		80.0					90.0	100.0
		250	ASF 40 X 250	1.02		100.0					112.5	125.0

JIS



JIS B 5012 SERIES



EXTRA LIGHT DUTY JIS COLOUR CODED **YELLOW**

CHARGE SUPER LÉGÈRE JIS COULEUR **JAUNE**

CARGA EXTRA LIGERA **AMARILLO** CÓDIGO COLOR SEGÚN JIS

EXTRA LEICHTE BEANSPRUCHUNG JIS FARBUNTERLEGTES **GELB**

CARICO EXTRA PESANTE CODICE CROMATICO JIS **GIALLO**

CARGA EXTRA LEVE COR DA SÉRIE JIS **AMARELO**

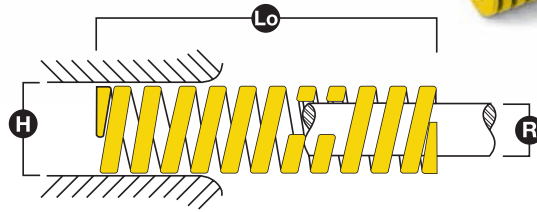

H	R	Lo	Part No.	P/f	L ₁ 32%		L ₂ 36%		L ₃ 40%	
					N	D	N	D	N	D
50	25	50	ASF 50 X 50	8.00	1,569	20.0	1,765	22.5	1,961	25.0
		60	ASF 50 X 60	6.66		24.0		27.0		30.0
		70	ASF 50 X 70	5.71		28.0		31.5		35.0
		80	ASF 50 X 80	5.00		32.0		36.0		40.0
		90	ASF 50 X 90	4.44		36.0		40.5		45.0
		100	ASF 50 X 100	4.00		40.0		45.0		50.0
		125	ASF 50 X 125	3.20		50.0		56.2		63.5
		150	ASF 50 X 150	2.66		60.0		67.5		75.0
		175	ASF 50 X 175	2.28		70.0		78.7		87.5
		200	ASF 50 X 200	2.00		80.0		90.0		100.0
		250	ASF 50 X 250	1.60		100.0		112.5		125.0
		300	ASF 50 X 300	1.33		120.0		135.0		150.0
		350	ASF 50 X 350	1.14		140.0		157.5		175.0
		400	ASF 50 X 400	1.00		160.0		180.0		200.0
450	ASF 50 X 450	0.89	180.0	202.5	225.0					
500	ASF 50 X 500	0.80	200.0	225.0	250.0					
60	33	60	ASF 60 X 60	9.59	2,260	24.0	2,540	27.0	2,820	30.0
		70	ASF 60 X 70	8.22		28.0		31.5		35.0
		80	ASF 60 X 80	7.19		32.0		36.0		40.0
		90	ASF 60 X 90	6.40		36.0		40.5		45.0
		100	ASF 60 X 100	5.76		40.0		45.0		50.0
		125	ASF 60 X 125	4.60		50.0		56.2		62.5
		150	ASF 60 X 150	3.84		60.0		67.5		75.0
		175	ASF 60 X 175	3.29		70.0		78.7		87.5
		200	ASF 60 X 200	2.88		80.0		90.0		100.0
		250	ASF 60 X 250	2.30		100.0		112.5		125.0
		300	ASF 60 X 300	1.92		120.0		135.0		150.0
		350	ASF 60 X 350	1.65		140.0		157.5		175.0
		400	ASF 60 X 400	1.44		160.0		180.0		200.0
		450	ASF 60 X 450	1.28		180.0		202.5		225.0
500	ASF 60 X 500	1.15	200.0	225.0	250.0					

JIS





NOTES

A large area of horizontal grey lines for taking notes, consisting of 25 rows.

JIS B 5012 SERIES

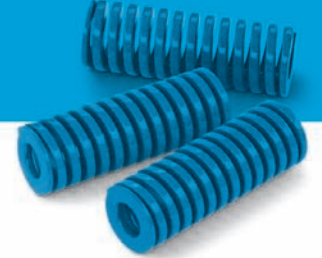

LIGHT DUTY JIS COLOUR CODED **BLUE**

CHARGE LÉGÈRE JIS COULEUR **BLEUE**

CARGA LIGERA **AZUL** CÓDIGO COLOR SEGÚN JIS

LEICHTE BEANSPRUCHUNG JIS FARBUNTERLEGTES **BLAU**

CARICO LEGGERO CODICE CROMATICO JIS **BLU**

CARGA LEVE COR DA SÉRIE JIS **AZUL**

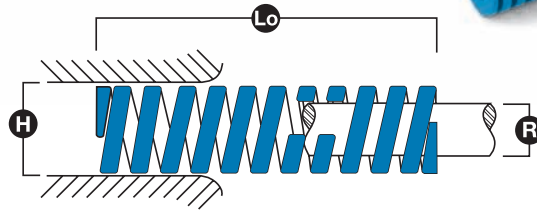

H	R	Lo	Part No.	P/f	L ₁ 32%		L ₂ 36%		L ₃ 40%	
					N	D	N	D	N	D
8	4	10	ASL 8 X 10	2.50	79	3.2	88	3.6	98	4.0
		15	ASL 8 X 15	1.67		4.8		5.4		6.0
		20	ASL 8 X 20	1.25		6.4		7.2		8.0
		25	ASL 8 X 25	1.00		8.0		9.0		10.0
		30	ASL 8 X 30	0.83		9.6		10.8		12.0
		35	ASL 8 X 35	0.71		11.2		12.6		14.0
		40	ASL 8 X 40	0.63		12.8		14.4		16.0
		45	ASL 8 X 45	0.56		14.4		16.2		18.0
		50	ASL 8 X 50	0.50		16.0		18.0		20.0
		55	ASL 8 X 55	0.46		17.6		19.8		22.0
		60	ASL 8 X 60	0.42	19.2	21.6	24.0			
10	5	20	ASL 10 X 20	1.81	113	6.4	128	7.2	142	8.0
		25	ASL 10 X 25	1.45		8.0		9.0		10.0
		30	ASL 10 X 30	1.21		9.6		10.8		12.0
		35	ASL 10 X 35	1.03		11.2		12.6		14.0
		40	ASL 10 X 40	0.90		12.8		14.4		16.0
		45	ASL 10 X 45	0.80		14.4		16.2		18.0
		50	ASL 10 X 50	0.73		16.0		18.0		20.0
		55	ASL 10 X 55	0.66		17.6		19.8		22.0
		60	ASL 10 X 60	0.60		19.2		21.6		24.0
		65	ASL 10 X 65	0.55		20.8		23.4		26.0
		70	ASL 10 X 70	0.51	22.4	25.2	28.0			
		75	ASL 10 X 75	0.48	24.0	27.0	30.0			
		80	ASL 10 X 80	0.45	25.6	28.8	32.0			
12	6	20	ASL 12 X 20	2.63	167	6.4	186	7.2	206	8.0
		25	ASL 12 X 25	2.10		8.0		9.0		10.0
		30	ASL 12 X 30	1.75		9.6		10.8		12.0
		35	ASL 12 X 35	1.50		11.2		12.6		14.0
		40	ASL 12 X 40	1.32		12.8		14.4		16.0
		45	ASL 12 X 45	1.17		14.4		16.2		18.0
		50	ASL 12 X 50	1.05		16.0		18.0		20.0
		55	ASL 12 X 55	0.96		17.6		19.8		22.0
		60	ASL 12 X 60	0.88		19.2		21.6		24.0
		65	ASL 12 X 65	0.81		20.8		23.4		26.0
		70	ASL 12 X 70	0.75	22.4	25.2	28.0			
		75	ASL 12 X 75	0.70	24.0	27.0	30.0			
		80	ASL 12 X 80	0.66	25.6	28.8	32.0			
14	7	25	ASL 14 X 25	2.80	216	8.0	245	9.0	275	10.0
		30	ASL 14 X 30	2.34		9.6		10.8		12.0
		35	ASL 14 X 35	2.00		11.2		12.6		14.0
		40	ASL 14 X 40	1.75		12.8		14.4		16.0
		45	ASL 14 X 45	1.56		14.4		16.2		18.0
		50	ASL 14 X 50	1.40		16.0		8.0		20.0
		55	ASL 14 X 55	1.27		17.6		19.8		22.0
		60	ASL 14 X 60	1.17		19.2		21.6		24.0
		65	ASF 14 X 65	1.08		20.8		23.4		26.0
		70	ASL 14 X 70	1.00		22.4		25.2		28.0
		75	ASL 14 X 75	0.93		24.0		27.0		30.0
		80	ASL 14 X 80	0.87		25.6		28.8		32.0
		90	ASL 14 X 90	0.77	28.8	32.4	36.0			

JIS

JIS B 5012 SERIES

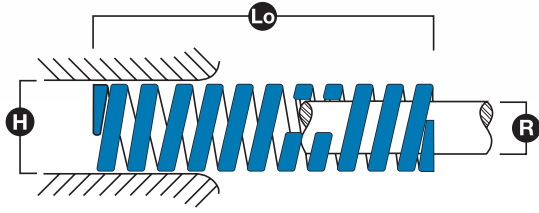
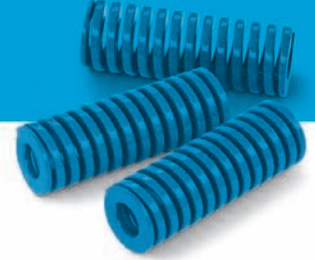

H	R	Lo	Part No.	P/f	L ₁ 32%		L ₂ 36%		L ₃ 40%	
					N	D	N	D	N	D
16	8	25	ASL 16 X 25	3.50	275	8.0	314	9.0	343	10.0
		30	ASL 16 X 30	2.92		9.6		10.8		12.0
		35	ASL 16 X 35	2.50		11.2		12.6		14.0
		40	ASL 16 X 40	2.19		12.8		14.4		16.0
		45	ASL 16 X 45	1.95		14.4		16.2		18.0
		50	ASL 16 X 50	1.75		16.0		18.0		20.0
		55	ASL 16 X 55	1.60		17.6		19.8		22.0
		60	ASL 16 X 60	1.46		19.2		21.6		24.0
		65	ASL 16 X 65	1.35		20.8		23.4		26.0
		70	ASL 16 X 70	1.25		22.4		25.0		28.0
		75	ASL 16 X 75	1.17		24.0		27.0		30.0
		80	ASL 16 X 80	1.10		25.6		28.8		32.0
90	ASL 16 X 90	0.98	28.8	32.4	36.0					
100	ASL 16 X 100	0.88	32.0	36.0	40.0					
18	9	25	ASL 18 X 25	4.30	333	8.0	382	9.0	422	10.0
		30	ASL 18 X 30	3.58		9.6		10.8		12.0
		35	ASL 18 X 35	3.07		11.2		12.6		14.0
		40	ASL 18 X 40	2.69		12.8		14.4		16.0
		45	ASL 18 X 45	2.39		14.4		16.2		18.0
		50	ASL 18 X 50	2.15		16.0		18.0		20.0
		55	ASL 18 X 55	1.96		17.6		19.8		22.0
		60	ASL 18 X 60	1.79		19.2		21.6		24.0
		65	ASL 18 X 65	1.66		20.8		23.4		26.0
		70	ASL 18 X 70	1.54		22.4		25.2		28.0
		75	ASL 18 X 75	1.44		24.0		27.0		30.0
		80	ASL 18 X 80	1.35		25.6		28.8		32.0
90	ASL 18 X 90	1.20	28.8	32.4	36.0					
100	ASL 18 X 100	1.07	32.0	36.0	40.0					
20	10	25	ASL 20 X 25	5.40	422	8.0	481	9.0	530	10.0
		30	ASL 20 X 30	4.50		9.6		10.8		12.0
		35	ASL 20 X 35	3.86		11.2		12.6		14.0
		40	ASL 20 X 40	3.38		12.8		14.4		16.0
		45	ASL 20 X 45	3.00		14.4		16.2		18.0
		50	ASL 20 X 50	2.70		16.0		18.0		20.0
		55	ASL 20 X 55	2.45		17.6		19.8		22.0
		60	ASL 20 X 60	2.25		19.2		21.6		24.0
		65	ASL 20 X 65	2.08		20.8		23.4		26.0
		70	ASL 20 X 70	1.93		22.4		25.2		28.0
		75	ASL 20 X 75	1.80		24.0		27.0		30.0
		80	ASL 20 X 80	1.69		25.6		28.8		32.0
		90	ASL 20 X 90	1.50		28.8		32.4		36.0
		100	ASL 20 X 100	1.35		32.0		36.0		40.0
		125	ASL 20 X 125	1.08		40.0		45.0		50.0
150	ASL 20 X 150	0.90	48.0	54.0	60.0					

JIS B 5012 SERIES



LIGHT DUTY JIS COLOUR CODED **BLUE**

CHARGE LÉGÈRE JIS COULEUR **BLEUE**

CARGA LIGERA **AZUL** CÓDIGO COLOR SEGÚN JIS

LEICHTE BEANSPRUCHUNG JIS FARBUNTERLEGTES **BLAU**

CARICO LEGGERO CODICE CROMATICO JIS **BLU**

CARGA LEVE COR DA SÉRIE JIS **AZUL**

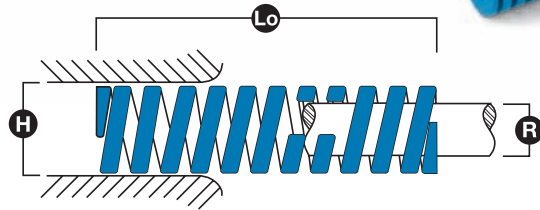

H	R	Lo	Part No.	P/f	L ₁ 32%		L ₂ 36%		L ₃ 40%	
					N	D	N	D	N	D
22	11	25	ASL 22 X 25	6.70	530	8.0	588	9.0	657	10.0
		30	ASL 22 X 30	5.60		9.6		10.8		12.0
		35	ASL 22 X 35	4.80		11.2		12.6		14.0
		40	ASL 22 X 40	4.20		12.8		14.4		16.0
		45	ASL 22 X 45	3.72		14.4		16.2		18.0
		50	ASL 22 X 50	3.35		16.0		18.0		20.0
		55	ASL 22 X 55	3.05		17.6		19.8		22.0
		60	ASL 22 X 60	2.80		19.2		21.6		24.0
		65	ASL 22 X 65	2.58		20.8		23.4		26.0
		70	ASL 22 X 70	2.40		22.4		25.2		28.0
		75	ASL 22 X 75	2.23		24.0		27.0		30.0
		80	ASL 22 X 80	2.10		25.6		28.8		32.0
		90	ASL 22 X 90	1.86		28.8		32.4		36.0
		100	ASL 22 X 100	1.68		32.0		36.0		40.0
		125	ASL 22 X 125	1.34		40.0		45.0		50.0
150	ASL 22 X 150	1.12	48.0	54.0	60.0					
25	12.5	25	ASL 25 X 25	8.40	657	8.0	745	9.0	824	10.0
		30	ASL 25 X 30	7.00		9.6		10.8		12.0
		35	ASL 25 X 35	6.00		11.2		12.6		14.0
		40	ASL 25 X 40	5.25		12.8		14.4		16.0
		45	ASL 25 X 45	4.67		14.4		16.2		18.0
		50	ASL 25 X 50	4.20		16.0		18.0		20.0
		55	ASL 25 X 55	3.82		17.6		19.8		22.0
		60	ASL 25 X 60	3.50		19.2		21.6		24.0
		65	ASL 25 X 65	3.23		20.8		23.4		26.0
		70	ASL 25 X 70	3.00		22.4		25.2		28.0
		75	ASL 25 X 75	2.80		24.0		27.0		30.0
		80	ASL 25 X 80	2.63		25.6		28.8		32.0
		90	ASL 25 X 90	2.33		28.8		32.4		36.0
		100	ASL 25 X 100	2.10		32.0		36.0		40.0
		125	ASL 25 X 125	1.68		40.0		45.0		50.0
150	ASL 25 X 150	1.40	48.0	54.0	60.0					
175	ASL 25 X 175	1.20	56.0	63.0	70.0					
27	13.5	25	ASL 27 X 25	10.00	795	8.0	883	9.0	981	10.0
		30	ASL 27 X 30	8.33		9.6		10.8		12.0
		35	ASL 27 X 35	7.14		11.2		12.6		14.0
		40	ASL 27 X 40	6.25		12.8		14.4		16.0
		45	ASL 27 X 45	5.56		14.4		16.2		18.0
		50	ASL 27 X 50	5.00		16.0		18.0		20.0
		55	ASL 27 X 55	4.55		17.6		19.8		22.0
		60	ASL 27 X 60	4.17		19.2		21.6		24.0
		65	ASL 27 X 65	3.85		20.8		23.4		26.0
		70	ASL 27 X 70	3.57		22.4		25.2		28.0
		75	ASL 27 X 75	3.33		24.0		27.0		30.0
		80	ASL 27 X 80	3.13		25.6		28.8		32.0
		90	ASL 27 X 90	2.78		28.8		32.4		36.0
		100	ASL 27 X 100	2.50		32.0		36.0		40.0
		125	ASL 27 X 125	2.00		40.0		45.0		50.0
150	ASL 27 X 150	1.67	48.0	54.0	60.0					
175	ASL 27 X 175	1.43	56.0	63.0	70.0					

JIS



JIS B 5012 SERIES

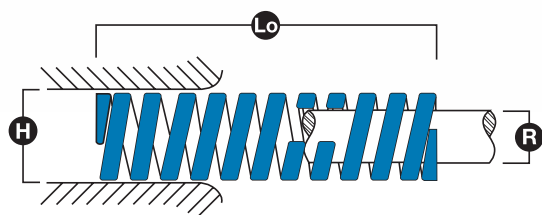

H	R	Lo	Part No.	P/f	L ₁ 32%		L ₂ 36%		L ₃ 40%	
					N	D	N	D	N	D
30	15	25	ASL 30 X 25	12.11	951	8.0	1,069	9.0	1,187	10.0
		30	ASL 30 X 30	10.08		9.6		10.8		12.0
		35	ASL 30 X 35	8.65		11.2		12.6		14.0
		40	ASL 30 X 40	7.56		12.8		14.4		16.0
		45	ASL 30 X 45	6.73		14.4		16.2		18.0
		50	ASL 30 X 50	6.05		16.0		18.0		20.0
		55	ASL 30 X 55	5.50		17.6		19.8		22.0
		60	ASL 30 X 60	5.04		19.2		21.6		24.0
		65	ASL 30 X 65	4.65		20.8		23.4		26.0
		70	ASL 30 X 70	4.32		22.4		25.2		28.0
		75	ASL 30 X 75	4.03		24.0		27.0		30.0
		80	ASL 30 X 80	3.78		25.6		28.8		32.0
		90	ASL 30 X 90	3.36		28.8		32.4		36.0
		100	ASL 30 X 100	3.02		32.0		36.0		40.0
		125	ASL 30 X 125	2.42		40.0		45.0		50.0
150	ASL 30 X 150	2.01	48.0	54.0	60.0					
175	ASL 30 X 175	1.72	56.0	63.0	70.0					
200	ASL 30 X 200	1.51	64.0	72.0	80.0					
35	17.5	40	ASL 35 X 40	10.31	1,295	12.8	1,461	14.4	1,618	16.0
		45	ASF 35 X 45	9.17		14.4		16.2		18.0
		50	ASL 35 X 50	8.25		16.0		18.0		20.0
		55	ASL 35 X 55	7.50		17.6		19.8		22.0
		60	ASL 35 X 60	6.87		19.2		21.6		24.0
		65	ASF 35 X 65	6.35		20.8		23.4		26.0
		70	ASL 35 X 70	5.89		22.4		25.2		28.0
		75	ASL 35 X 75	5.50		24.0		27.0		30.0
		80	ASL 35 X 80	5.15		25.6		28.8		32.0
		90	ASF 35 X 90	4.58		28.8		32.4		36.0
		100	ASL 35 X 100	4.12		32.0		36.0		40.0
		125	ASL 35 X 125	3.30		40.0		45.0		50.0
150	ASL 35 X 150	2.75	48.0	54.0	60.0					
175	ASL 35 X 175	2.35	56.0	63.0	70.0					
200	ASL 35 X 200	2.06	64.0	72.0	80.0					
40	20	40	ASL 40 X 40	13.50	1,697	12.8	1,903	14.4	2,120	16.0
		50	ASL 40 X 50	10.80		16.0		18.0		20.0
		60	ASL 40 X 60	9.00		19.2		21.6		24.0
		70	ASL 40 X 70	7.71		22.4		25.2		28.0
		80	ASL 40 X 80	6.75		25.6		28.8		32.0
		90	ASL 40 X 90	6.00		28.8		32.4		36.0
		100	ASL 40 X 100	5.40		32.0		36.0		40.0
		125	ASL 40 X 125	4.32		40.0		45.0		50.0
		150	ASL 40 X 150	3.60		48.0		54.0		60.0
		175	ASL 40 X 175	3.08		56.0		63.0		70.0
		200	ASL 40 X 200	2.70		64.0		72.0		80.0
250	ASL 40 X 250	2.16	80.0	90.0	100.0					

JIS



JIS B 5012 SERIES



LIGHT DUTY JIS COLOUR CODED **BLUE**

CHARGE LÉGÈRE JIS COULEUR **BLEUE**

CARGA LIGERA **AZUL** CÓDIGO COLOR SEGÚN JIS

LEICHTE BEANSPRUCHUNG JIS FARBUNTERLEGTES **BLAU**

CARICO LEGGERO CODICE CROMATICO JIS **BLU**

CARGA LEVE COR DA SÉRIE JIS **AZUL**

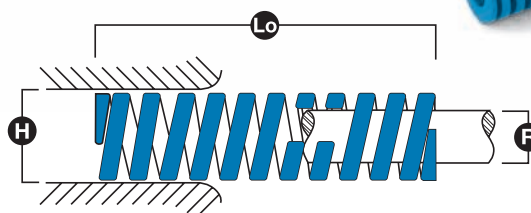

H	R	Lo	Part No.	P/f	L ₁ 32%		L ₂ 36%		L ₃ 40%	
					N	D	N	D	N	D
50	25	50	ASL 50 X 50	16.89	2,650	16.0	2,980	18.0	3,310	20.0
		60	ASL 50 X 60	14.08		19.2		21.6		24.0
		70	ASL 50 X 70	12.07		22.4		25.2		28.0
		80	ASL 50 X 80	10.56		25.6		28.8		32.0
		90	ASL 50 X 90	9.38		28.8		32.4		36.0
		100	ASL 50 X 100	8.45		32.0		36.0		40.0
		125	ASL 50 X 125	6.76		40.0		45.0		50.0
		150	ASL 50 X 150	5.63		48.0		54.0		60.0
		175	ASL 50 X 175	4.82		56.0		63.0		70.0
		200	ASL 50 X 200	4.22		64.0		72.0		80.0
		250	ASL 50 X 250	3.38		80.0		90.0		100.0
		300	ASL 50 X 300	2.81		96.0		108.0		120.0
		350	ASL 50 X 350	2.41		112.0		126.0		140.0
		400	ASL 50 X 400	2.11		128.0		144.0		160.0
450	ASL 50 X 450	1.88	144.0	162.0	180.0					
500	ASL 50 X 500	1.69	160.0	180.0	200.0					
60	30	60	ASL 60 X 60	20.25	3,810	19.2	4,290	21.6	4,770	24.0
		70	ASL 60 X 70	17.35		22.4		25.2		28.0
		80	ASL 60 X 80	15.18		25.6		28.8		32.0
		90	ASL 60 X 90	13.50		28.8		32.4		36.0
		100	ASL 60 X 100	12.15		32.0		36.0		40.0
		125	ASL 60 X 125	9.72		40.0		45.0		50.0
		150	ASL 60 X 150	8.10		48.0		54.0		60.0
		175	ASL 60 X 175	6.94		56.0		63.0		70.0
		200	ASL 60 X 200	6.07		64.0		72.0		80.0
		250	ASL 60 X 250	4.86		80.0		90.0		100.0
		300	ASL 60 X 300	4.05		96.0		108.0		120.0
		350	ASL 60 X 350	3.47		112.0		126.0		140.0
		400	ASL 60 X 400	3.04		128.0		144.0		160.0
		450	ASL 60 X 450	2.70		144.0		162.0		180.0
500	ASL 60 X 500	2.43	160.0	180.0	200.0					



NOTES

A large area of horizontal grey lines for taking notes, spanning most of the page width and height.

JIS B 5012 SERIES

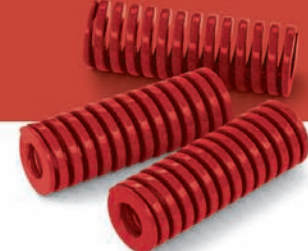

MEDIUM DUTY JIS COLOUR CODED **RED**

CHARGE MOYENNE JIS COULEUR **ROUGE**

CARGA MEDIA **ROJO** CÓDIGO COLOR SEGÚN JIS

MITTLERE BEANSPRUCHUNG JIS FARBUNTERLEGTES **ROT**

CARICO MEDIO CODICE CROMATICO JIS **ROSSO**

CARGA MEDIA COR DA SÉRIE JIS **VERMELHO**

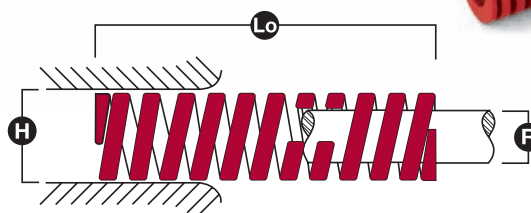

H	R	Lo	Part No.	P/f	L ₁ 26%		L ₂ 29%		L ₃ 32%	
					N	D	N	D	N	D
8	4	10	ASM 8 X 10	4.34	108	2.6	123	2.9	137	4.0
		15	ASM 8 X 15	2.89		3.8		4.3		6.0
		20	ASM 8 X 20	2.17		5.1		5.8		8.0
		25	ASM 8 X 25	1.74		6.4		7.2		10.0
		30	ASM 8 X 30	1.45		7.7		8.6		12.0
		35	ASM 8 X 35	1.24		9.0		10.1		14.0
		40	ASM 8 X 40	1.09		10.2		11.5		16.0
		45	ASM 8 X 45	0.97		11.5		13.0		18.0
		50	ASM 8 X 50	0.87		12.8		14.4		20.0
		55	ASM 8 X 55	0.79		14.1		15.8		22.0
		60	ASM 8 X 60	0.72	15.4	17.3	19.0	24.0		
10	5	20	ASM 10 X 20	3.13	157	5.1	177	5.8	196	8.0
		25	ASM 10 X 25	2.50		6.4		7.2		10.0
		30	ASM 10 X 30	2.08		7.7		8.6		12.0
		35	ASM 10 X 35	1.78		9.0		10.1		14.0
		40	ASM 10 X 40	1.56		10.2		11.5		16.0
		45	ASM 10 X 45	1.38		11.5		13.0		18.0
		50	ASM 10 X 50	1.25		12.8		14.4		20.0
		55	ASM 10 X 55	1.13		14.1		15.8		22.0
		60	ASM 10 X 60	1.04		15.4		17.3		24.0
		65	ASM 10 X 65	0.96		16.6		18.7		26.0
		70	ASM 10 X 70	0.89	17.9	20.2	22.0	28.0		
		75	ASM 10 X 75	0.83	19.2	21.6	24.0	30.0		
		80	ASM 10 X 80	0.78	20.5	23.0	26.0	32.0		
12	6	20	ASM 12 X 20	4.53	226	5.1	255	5.8	284	8.0
		25	ASM 12 X 25	3.62		6.4		7.2		10.0
		30	ASM 12 X 30	3.02		7.7		8.6		12.0
		35	ASM 12 X 35	2.58		9.0		10.1		14.0
		40	ASM 12 X 40	2.27		10.2		11.5		16.0
		45	ASM 12 X 45	2.01		11.5		13.0		18.0
		50	ASM 12 X 50	1.81		12.8		14.4		20.0
		55	ASM 12 X 55	1.64		14.1		15.8		22.0
		60	ASM 12 X 60	1.51		15.4		17.3		24.0
		65	ASM 12 X 65	1.39		16.6		18.7		26.0
		70	ASM 12 X 70	1.29	17.9	20.2	22.0	28.0		
		75	ASM 12 X 75	1.20	19.2	21.6	24.0	30.0		
		80	ASM 12 X 80	1.13	20.5	23.0	26.0	32.0		
14	7	25	ASM 14 X 25	4.87	304	6.4	343	7.2	383	10.0
		30	ASM 14 X 30	4.06		7.7		8.6		12.0
		35	ASM 14 X 35	3.48		9.0		10.1		14.0
		40	ASM 14 X 40	3.04		10.2		11.5		16.0
		45	ASM 14 X 45	2.70		11.5		13.0		18.0
		50	ASM 14 X 50	2.43		12.8		14.4		20.0
		55	ASM 14 X 55	2.21		14.1		15.8		22.0
		60	ASM 14 X 60	2.03		15.4		17.3		24.0
		65	ASM 14 X 65	1.87		16.6		18.7		26.0
		70	ASM 14 X 70	1.74		17.9		20.2		28.0
		75	ASM 14 X 75	1.62	19.2	21.6	24.0	30.0		
		80	ASM 14 X 80	1.52	20.5	23.0	26.0	32.0		
		90	ASM 14 X 90	1.35	23.0	25.9	28.0	36.0		

JIS



JIS B 5012 SERIES



H	R	Lo	Part No.	P/f	L ₁ 26%		L ₂ 29%		L ₃ 32%	
					N	D	N	D	N	D
16	8	25	ASM 16 X 25	6.39	402	6.4	451	7.2	500	8.0
		30	ASM 16 X 30	5.32		7.7		8.6		9.6
		35	ASM 16 X 35	4.65		9.0		10.1		11.2
		40	ASM 16 X 40	3.98		10.2		11.5		12.8
		45	ASM 16 X 45	3.54		11.5		13.0		14.4
		50	ASM 16 X 50	3.18		12.8		14.4		16.0
		55	ASM 16 X 55	2.89		14.1		15.8		17.6
		60	ASM 16 X 60	2.65		15.4		17.3		19.2
		65	ASM 16 X 65	2.45		16.6		18.7		20.8
		70	ASM 16 X 70	2.27		17.9		20.2		22.4
		75	ASM 16 X 75	2.11		19.2		21.6		24.0
		80	ASM 16 X 80	1.99		20.5		23.0		25.6
90	ASM 16 X 90	1.77	23.0	25.9	28.8					
100	ASM 16 X 100	1.59	25.6	28.8	32.0					
18	9	25	ASM 18 X 25	8.12	510	6.4	569	7.2	637	8.0
		30	ASM 18 X 30	6.77		7.7		8.6		9.6
		35	ASM 18 X 35	5.80		9.0		10.1		11.2
		40	ASM 18 X 40	5.07		10.2		11.5		12.8
		45	ASM 18 X 45	4.51		11.5		13.0		14.4
		50	ASM 18 X 50	4.06		12.8		14.4		16.0
		55	ASM 18 X 55	3.69		14.1		15.8		17.6
		60	ASM 18 X 60	3.38		15.4		17.3		19.2
		65	ASM 18 X 65	3.12		16.6		18.7		20.8
		70	ASM 18 X 70	2.90		17.9		20.2		22.4
		75	ASM 18 X 75	2.70		19.2		21.6		24.0
		80	ASM 18 X 80	2.53		20.5		23.0		25.6
90	ASM 18 X 90	2.25	23.0	25.9	28.8					
100	ASM 18 X 100	2.02	25.6	28.8	32.0					
20	10	25	ASM 20 X 25	10.00	628	6.4	706	7.2	785	8.0
		30	ASM 20 X 30	8.33		7.7		8.6		9.6
		35	ASM 20 X 35	7.14		9.0		10.1		11.2
		40	ASM 20 X 40	6.25		10.2		11.5		12.8
		45	ASM 20 X 45	5.55		11.5		13.0		14.4
		50	ASM 20 X 50	5.00		12.8		14.4		16.0
		55	ASM 20 X 55	4.54		14.1		15.8		17.6
		60	ASM 20 X 60	4.16		15.4		17.3		19.2
		65	ASM 20 X 65	3.84		16.6		18.7		20.8
		70	ASM 20 X 70	3.57		17.9		20.2		22.4
		75	ASM 20 X 75	3.33		19.2		21.6		24.0
		80	ASM 20 X 80	3.12		20.5		23.0		25.6
		90	ASM 20 X 90	2.77		23.0		25.9		28.8
		100	ASM 20 X 100	2.50		25.6		28.8		32.0
		125	ASM 20 X 125	2.00		32.0		36.0		40.0
150	ASM 20 X 150	1.67	38.4	43.2	48.0					

JIS B 5012 SERIES



MEDIUM DUTY JIS COLOUR CODED **RED**

CHARGE MOYENNE JIS COULEUR **ROUGE**

CARGA MEDIA **ROJO** CÓDIGO COLOR SEGÚN JIS

MITTLERE BEANSPRUCHUNG JIS FARBUNTERLEGTES **ROT**

CARICO MEDIO CODICE CROMATICO JIS **ROSSO**

CARGA MEDIA COR DA SÉRIE JIS **VERMELHO**

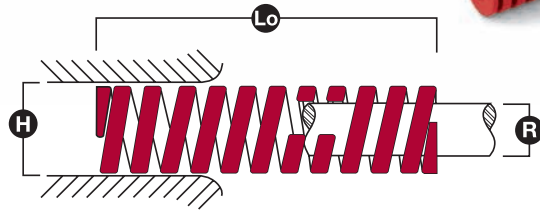

H	R	Lo	Part No.	P/f	L ₁ 26%		L ₂ 29%		L ₃ 32%	
					N	D	N	D	N	D
22	11	25	ASM 22 X 25	12.13	765	6.4	853	7.2	951	8.0
		30	ASM 22 X 30	10.10		7.7		8.6		9.6
		35	ASM 22 X 35	8.65		9.0		10.1		11.2
		40	ASM 22 X 40	7.57		10.2		11.5		12.8
		45	ASM 22 X 45	6.74		11.5		13.0		14.4
		50	ASM 22 X 50	6.06		12.8		14.4		16.0
		55	ASM 22 X 55	5.50		14.1		15.8		17.6
		60	ASM 22 X 60	5.05		15.4		17.3		19.2
		65	ASM 22 X 65	4.66		16.6		18.7		20.8
		70	ASM 22 X 70	4.33		17.0		20.2		22.4
		75	ASM 22 X 75	4.04		19.2		21.6		24.0
		80	ASM 22 X 80	3.78		20.5		23.0		25.6
		90	ASM 22 X 90	3.36		23.0		25.9		28.8
		100	ASM 22 X 100	3.03		25.6		28.8		32.0
		125	ASM 22 X 125	2.42		32.0		36.0		40.0
150	ASM 22 X 150	2.01	38.4	43.2	48.0					
25	12.5	25	ASM 25 X 25	15.63	981	6.4	1,098	7.2	1,226	8.0
		30	ASM 25 X 30	13.02		7.7		8.6		9.6
		35	ASM 25 X 35	11.20		9.0		10.0		11.2
		40	ASM 25 X 40	9.76		10.2		11.5		12.8
		45	ASM 25 X 45	8.68		11.5		13.0		14.4
		50	ASM 25 X 50	7.81		12.8		14.4		16.0
		55	ASM 25 X 55	7.10		14.1		15.8		17.6
		60	ASM 25 X 60	6.51		15.4		17.3		19.2
		65	ASM 25 X 65	6.00		16.6		18.7		20.8
		70	ASM 25 X 70	5.58		17.9		20.2		22.4
		75	ASM 25 X 75	5.21		19.2		21.6		24.0
		80	ASM 25 X 80	4.88		20.5		23.0		25.6
		90	ASM 25 X 90	4.34		23.0		25.9		28.8
		100	ASM 25 X 100	3.90		25.6		28.8		32.0
		125	ASM 25 X 125	3.12		32.0		36.0		40.0
150	ASM 25 X 150	2.60	38.4	43.2	48.0					
175	ASM 25 X 175	2.23	44.8	50.4	56.0					
27	13.5	25	ASM 27 X 25	18.25	1,147	6.4	1,285	7.2	1,432	8.0
		30	ASM 27 X 30	15.20		7.7		8.6		9.6
		35	ASM 27 X 35	13.04		9.0		10.0		11.2
		40	ASM 27 X 40	11.40		10.2		11.5		12.8
		45	ASM 27 X 45	10.14		11.5		13.0		14.4
		50	ASM 27 X 50	9.12		12.8		14.4		16.0
		55	ASM 27 X 55	8.30		14.1		15.8		17.6
		60	ASM 27 X 60	7.60		15.4		17.3		19.2
		65	ASM 27 X 65	7.00		16.6		18.7		20.8
		70	ASM 27 X 70	6.51		17.9		20.2		22.4
		75	ASM 27 X 75	6.08		19.2		21.6		24.0
		80	ASM 27 X 80	5.70		20.5		23.0		25.6
		90	ASM 27 X 90	5.06		23.0		25.9		28.8
		100	ASM 27 X 100	4.56		25.7		28.8		32.0
		125	ASM 27 X 125	3.65		32.0		36.0		40.0
150	ASM 27 X 150	3.04	38.4	43.2	48.0					
175	ASM 27 X 175	2.61	44.8	50.4	56.0					

JIS



JIS B 5012 SERIES



H	R	Lo	Part No.	P/f	L ₁ 26%		L ₂ 29%		L ₃ 32%	
					N	D	N	D	N	D
30	15	25	ASM 30 X 25	22.50	1,412	6.4	1,579	7.2	1,765	8.0
		30	ASM 30 X 30	18.75		7.7		8.6		9.6
		35	ASM 30 X 35	16.10		9.0		10.0		11.2
		40	ASM 30 X 40	14.06		10.2		11.5		12.8
		45	ASM 30 X 45	12.50		11.5		13.0		14.4
		50	ASM 30 X 50	11.25		12.8		14.4		16.0
		55	ASM 30 X 55	10.23		14.1		15.8		17.6
		60	ASM 30 X 60	9.37		15.4		17.3		19.2
		65	ASM 30 X 65	8.65		16.6		18.7		20.8
		70	ASM 30 X 70	8.03		17.9		20.2		22.4
		75	ASM 30 X 75	7.50		19.2		21.6		24.0
		80	ASM 30 X 80	7.03		20.5		23.0		25.6
		90	ASM 30 X 90	6.25		23.0		25.9		28.8
		100	ASM 30 X 100	5.63		25.6		28.8		32.0
		125	ASM 30 X 125	4.50		32.0		36.0		40.0
		150	ASM 30 X 150	3.75		38.4		43.2		48.0
175	ASM 30 X 175	3.21	44.8	50.4	56.0					
200	ASM 30 X 200	2.81	51.2	57.6	64.0					
35	17.5	40	ASM 35 X 40	19.14	1,912	10.2	2,160	11.5	2,400	12.8
		45	ASM 35 X 45	17.01		11.5		13.0		14.4
		50	ASM 35 X 50	15.31		12.8		14.4		16.0
		55	ASM 35 X 55	13.92		14.0		15.8		17.6
		60	ASM 35 X 60	12.76		15.4		17.3		19.2
		65	ASM 35 X 65	11.77		16.6		18.7		20.8
		70	ASM 35 X 70	10.93		17.9		20.2		22.4
		75	ASM 35 X 75	10.20		19.2		21.6		24.0
		80	ASM 35 X 80	9.57		20.5		23.0		25.6
		90	ASM 35 X 90	8.50		23.0		25.9		28.8
		100	ASM 35 X 100	7.65		25.6		28.8		32.0
		125	ASM 35 X 125	6.12		32.0		36.0		40.0
150	ASM 35 X 150	5.10	38.4	43.2	48.0					
175	ASM 35 X 175	4.37	44.8	50.4	56.0					
200	ASM 35 X 200	3.82	51.2	57.6	64.0					
40	20	40	ASM 40 X 40	25.02	2,510	10.2	2,820	11.5	3,140	12.8
		50	ASM 40 X 50	20.00		12.8		14.4		16.0
		60	ASM 40 X 60	16.60		15.4		17.3		19.2
		70	ASM 40 X 70	14.28		17.9		20.2		22.4
		80	ASM 40 X 80	12.50		20.5		23.0		25.6
		90	ASM 40 X 90	11.11		23.0		25.9		28.8
		100	ASM 40 X 100	10.00		25.6		28.8		32.0
		125	ASM 40 X 125	8.00		32.0		36.0		40.0
		150	ASM 40 X 150	6.66		38.4		43.2		48.0
		175	ASM 40 X 175	5.71		44.8		50.4		56.0
		200	ASM 40 X 200	5.00		51.2		57.6		64.0
		250	ASM 40 X 250	4.00		64.0		72.0		80.0

JIS B 5012 SERIES



MEDIUM DUTY JIS COLOUR CODED **RED**

CHARGE MOYENNE JIS COULEUR **ROUGE**

CARGA MEDIA **ROJO** CÓDIGO COLOR SEGÚN JIS

MITTLERE BEANSPRUCHUNG JIS FARBUNTERLEGTES **ROT**

CARICO MEDIO CODICE CROMATICO JIS **ROSSO**

CARGA MEDIA COR DA SÉRIE JIS **VERMELHO**

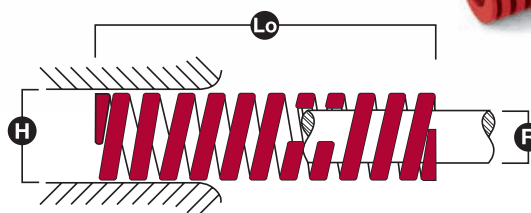

H	R	Lo	Part No.	P/f	L ₁ 26%		L ₂ 29%		L ₃ 32%	
					N	D	N	D	N	D
50	25	50	ASM 50 X 50	31.25	3,920	12.8	4,410	14.4	4,900	16.0
		60	ASM 50 X 60	26.04		15.4		17.3		19.2
		70	ASM 50 X 70	22.32		17.9		20.2		22.4
		80	ASM 50 X 80	19.53		20.5		23.0		25.6
		90	ASM 50 X 90	17.36		23.0		25.9		28.8
		100	ASM 50 X 100	15.62		25.6		28.8		32.0
		125	ASM 50 X 125	12.50		32.0		36.0		40.0
		150	ASM 50 X 150	10.41		38.4		43.2		48.0
		175	ASM 50 X 175	8.92		44.8		50.4		56.0
		200	ASM 50 X 200	7.81		51.2		57.6		64.0
		250	ASM 50 X 250	6.25		64.0		72.0		80.0
300	ASM 50 X 300	5.20	76.8	86.4	96.0					
60	30	60	ASM 60 X 60	37.40	5,640	15.4	6,350	17.3	7,060	19.2
		70	ASM 60 X 70	32.10		17.9		20.2		22.4
		80	ASM 60 X 80	28.12		20.5		23.0		25.6
		90	ASM 60 X 90	25.00		23.0		25.9		28.8
		100	ASM 60 X 100	22.50		25.6		28.8		32.0
		125	ASM 60 X 125	18.00		32.0		36.0		40.0
		150	ASM 60 X 150	15.00		38.4		43.2		48.0
		175	ASM 60 X 175	12.85		44.8		50.4		56.0
		200	ASM 60 X 200	11.25		51.2		57.6		64.0
		250	ASM 60 X 250	9.00		64.0		72.0		80.0
		300	ASM 60 X 300	7.50		76.8		86.4		96.0



NOTES

A large area consisting of 25 horizontal grey lines, intended for providing technical notes or specifications.

JIS B 5012 SERIES



HEAVY DUTY JIS COLOUR CODED **GREEN**

CHARGE FORTE JIS COULEUR **VERTE**

CARGA FUERTE **VERDE** CÓDIGO COLOR SEGÚN JIS

SCHWERE BEANSPRUCHUNG JIS FARBUNTERLEGTES **GRÜN**

CARICO PESANTE CODICE CROMATICO JIS **VERDE**

CARGA PESADA COR DA SÉRIE JIS **VERDE**

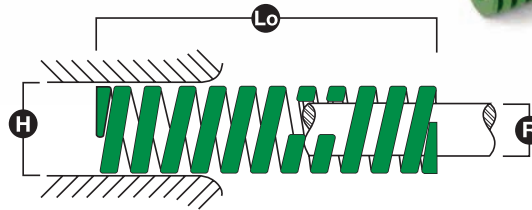

H	R	Lo	Part No.	P/f	L ₁ 19%		L ₂ 22%		L ₃ 24%	
					N	D	N	D	N	D
8	4	10	ASH 8 X 10	8.80	167	1.9	186	2.2	206	2.4
		15	ASH 8 X 15	5.86		2.9		3.2		3.6
		20	ASH 8 X 20	4.40		3.8		4.3		4.8
		25	ASH 8 X 25	3.52		4.8		5.4		6.0
		30	ASH 8 X 30	2.93		5.8		6.5		7.2
		35	ASH 8 X 35	2.51		6.7		7.5		8.4
		40	ASH 8 X 40	2.20		7.7		8.6		9.6
		45	ASH 8 X 45	1.95		8.6		9.7		10.8
		50	ASH 8 X 50	1.76		9.6		10.8		12.0
		55	ASH 8 X 55	1.60		10.6		11.8		13.2
		60	ASH 8 X 60	1.47	11.5	13.0	14.4			
10	5	20	ASH 10 X 20	6.25	235	3.8	265	4.3	294	4.8
		25	ASH 10 X 25	5.00		4.8		5.4		6.0
		30	ASH 10 X 30	4.16		5.8		6.5		7.2
		35	ASH 10 X 35	3.57		6.7		7.5		8.4
		40	ASH 10 X 40	3.15		7.7		8.6		9.6
		45	ASH 10 X 45	2.77		8.6		9.7		10.8
		50	ASH 10 X 50	2.50		9.6		10.8		12.0
		55	ASH 10 X 55	2.27		10.6		11.8		13.2
		60	ASH 10 X 60	2.08		11.5		13.0		14.4
		65	ASH 10 X 65	1.92		12.5		14.0		15.6
		70	ASH 10 X 70	1.79	13.4	15.1	16.8			
		75	ASH 10 X 75	1.67	14.4	16.2	18.0			
		80	ASH 10 X 80	1.56	15.4	17.3	19.2			
12	6	20	ASH 12 X 20	8.90	333	3.8	373	4.3	422	4.8
		25	ASH 12 X 25	7.10		4.8		5.4		6.0
		30	ASH 12 X 30	5.97		5.8		6.5		7.2
		35	ASH 12 X 35	5.11		6.7		7.5		8.4
		40	ASH 12 X 40	4.47		7.7		8.6		9.6
		45	ASH 12 X 45	3.98		8.6		9.7		10.8
		50	ASH 12 X 50	3.58		9.6		10.8		12.0
		55	ASH 12 X 55	3.25		10.6		11.8		13.2
		60	ASH 12 X 60	2.98		11.5		13.0		14.4
		65	ASH 12 X 65	2.74		12.5		14.0		15.6
		70	ASH 12 X 70	2.54	13.4	15.1	16.8			
		75	ASH 12 X 75	2.37	14.4	16.2	18.0			
		80	ASH 12 X 80	2.21	15.4	17.3	19.2			
14	7	25	ASH 14 X 25	9.83	461	4.8	520	5.4	579	6.0
		30	ASH 14 X 30	8.19		5.8		6.5		7.2
		35	ASH 14 X 35	7.02		6.7		7.5		8.4
		40	ASH 14 X 40	6.14		7.7		8.6		9.6
		45	ASH 14 X 45	5.46		8.6		9.7		10.8
		50	ASH 14 X 50	4.91		9.6		10.8		12.0
		55	ASH 14 X 55	4.46		10.6		11.8		13.2
		60	ASH 14 X 60	4.09		11.5		13.0		14.4
		65	ASH 14 X 65	3.78		12.5		14.0		15.6
		70	ASH 14 X 70	3.51		13.4		15.1		16.8
		75	ASH 14 X 75	3.27	14.4	16.2	18.0			
		80	ASH 14 X 80	3.07	15.4	17.3	19.2			
		90	ASH 14 X 90	2.72	17.3	19.4	21.6			

JIS



JIS B 5012 SERIES

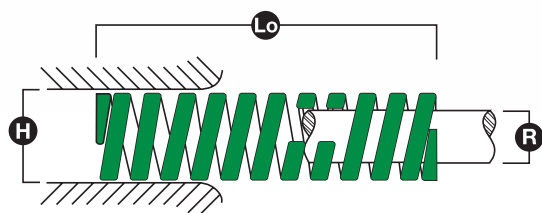

H	R	Lo	Part No.	P/f	L ₁ 19%		L ₂ 22%		L ₃ 24%	
					N	D	N	D	N	D
16	8	25	ASH 16 X 25	12.83	608	4.8	677	5.4	755	6.0
		30	ASH 16 X 30	10.69		5.8		6.5		7.2
		35	ASH 16 X 35	9.16		6.7		7.5		8.4
		40	ASH 16 X 40	8.02		7.7		8.6		9.6
		45	ASH 16 X 45	7.12		8.6		9.7		10.8
		50	ASH 16 X 50	6.41		9.6		10.8		12.0
		55	ASH 16 X 55	5.83		10.6		11.8		13.2
		60	ASH 16 X 60	5.34		11.5		13.0		14.4
		65	ASH 16 X 65	4.93		12.5		14.0		15.6
		70	ASH 16 X 70	4.58		13.4		15.1		16.8
		75	ASH 16 X 75	4.28		14.4		16.2		18.0
		80	ASH 16 X 80	4.01		15.4		17.3		19.2
90	ASH 16 X 90	3.57	17.3	19.4	21.6					
100	ASH 16 X 100	3.21	19.2	21.6	24.0					
18	9	25	ASH 18 X 25	16.16	765	4.8	853	5.4	951	6.0
		30	ASH 18 X 30	13.57		5.8		6.5		7.2
		35	ASH 18 X 35	11.54		6.7		7.5		8.4
		40	ASH 18 X 40	10.10		7.7		8.6		9.6
		45	ASH 18 X 45	8.98		8.6		9.7		10.8
		50	ASH 18 X 50	8.08		9.6		10.8		12.0
		55	ASH 18 X 55	7.34		10.6		11.8		13.2
		60	ASH 18 X 60	6.73		11.5		13.0		14.4
		65	ASH 18 X 65	6.21		12.5		14.0		15.6
		70	ASH 18 X 70	5.77		13.4		15.1		16.8
		75	ASH 18 X 75	5.39		14.4		16.2		18.0
		80	ASH 18 X 80	5.05		15.4		17.3		19.2
90	ASH 18 X 90	4.50	17.3	19.4	21.6					
100	ASH 18 X 100	4.04	19.2	21.6	24.0					
20	10	25	ASH 20 X 25	20.00	941	4.8	1,059	5.4	1,177	6.0
		30	ASH 20 X 30	16.66		5.8		6.5		7.2
		35	ASH 20 X 35	14.28		6.7		7.5		8.4
		40	ASH 20 X 40	12.50		7.7		8.6		9.6
		45	ASH 20 X 45	11.11		8.6		9.7		10.8
		50	ASH 20 X 50	10.00		9.6		10.8		12.0
		55	ASH 20 X 55	9.09		10.6		11.8		13.2
		60	ASH 20 X 60	8.33		11.5		13.0		14.4
		65	ASH 20 X 65	7.69		12.5		14.0		15.6
		70	ASH 20 X 70	7.14		13.4		15.1		16.8
		75	ASH 20 X 75	6.67		14.4		16.2		18.0
		80	ASH 20 X 80	6.25		15.4		17.3		19.2
		90	ASH 20 X 90	5.55		17.3		19.4		21.6
		100	ASH 20 X 100	5.00		19.2		21.6		24.0
		125	ASH 20 X 125	4.00		24.0		27.0		30.0
150	ASH 20 X 150	3.33	28.8	32.4	36.0					

JIS B 5012 SERIES



HEAVY DUTY JIS COLOUR CODED **GREEN**

CHARGE FORTE JIS COULEUR **VERTE**

CARGA FUERTE **VERDE** CÓDIGO COLOR SEGÚN JIS

SCHWERE BEANSPRUCHUNG JIS FARBUNTERLEGTES **GRÜN**

CARICO PESANTE CODICE CROMATICO JIS **VERDE**

CARGA PESADA COR DA SÉRIE JIS **VERDE**

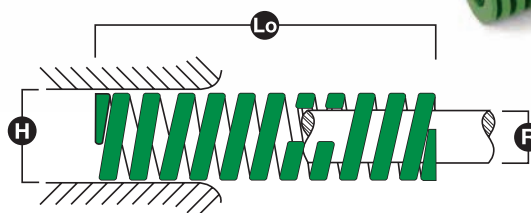

H	R	Lo	Part No.	P/f	L ₁ 19%		L ₂ 22%		L ₃ 24%	
					N	D	N	D	N	D
22	11	25	ASH 22 X 25	24.16	1,138	4.8	1,275	5.40	1,422	6.0
		30	ASH 22 X 30	20.13		5.8		6.50		7.2
		35	ASH 22 X 35	17.30		6.7		7.50		8.4
		40	ASH 22 X 40	15.10		7.7		8.60		9.6
		45	ASH 22 X 45	13.40		8.6		9.70		10.8
		50	ASH 22 X 50	12.08		9.6		10.80		12.0
		55	ASH 22 X 55	10.94		10.6		11.90		13.2
		60	ASH 22 X 60	10.06		11.5		13.00		14.4
		65	ASH 22 X 65	9.28		12.5		14.00		15.6
		70	ASH 22 X 70	8.63		13.4		15.10		16.8
		75	ASH 22 X 75	8.04		14.4		16.20		18.0
		80	ASH 22 X 80	7.55		15.4		17.30		19.2
		90	ASH 22 X 90	6.71		17.3		19.40		21.6
		100	ASH 22 X 100	6.04		19.2		21.60		24.0
		125	ASH 22 X 125	4.83		24.0		27.00		30.0
150	ASH 22 X 150	4.02	28.8	32.40	36.0					
25	12.5	25	ASH 25 X 25	31.20	1,471	4.8	1,657	5.40	1,834	6.0
		30	ASH 25 X 30	25.97		5.8		6.50		7.2
		35	ASH 25 X 35	22.38		6.7		7.50		8.4
		40	ASH 25 X 40	19.47		7.7		8.60		9.6
		45	ASH 25 X 45	17.40		8.6		9.70		10.8
		50	ASH 25 X 50	15.58		9.6		10.80		12.0
		55	ASH 25 X 55	14.20		10.6		11.90		13.2
		60	ASH 25 X 60	12.98		11.5		13.00		14.4
		65	ASH 25 X 65	12.00		12.5		14.00		15.6
		70	ASH 25 X 70	11.13		13.4		15.10		16.8
		75	ASH 25 X 75	10.40		14.4		16.20		18.0
		80	ASH 25 X 80	9.73		15.4		17.30		19.2
		90	ASH 25 X 90	8.65		17.3		19.40		21.6
		100	ASH 25 X 100	7.79		19.2		21.60		24.0
		125	ASH 25 X 125	6.23		24.0		27.00		30.0
150	ASH 25 X 150	5.20	28.8	32.40	36.0					
175	ASH 25 X 175	4.46	33.6	37.80	42.0					
27	13.5	25	ASH 27 X 25	36.40	1,716	4.8	1,932	5.40	2,150	6.0
		30	ASH 27 X 30	30.41		5.8		6.50		7.2
		35	ASH 27 X 35	26.20		6.7		7.50		8.4
		40	ASH 27 X 40	22.81		7.7		8.60		9.6
		45	ASH 27 X 45	20.30		8.6		9.70		10.8
		50	ASH 27 X 50	18.25		9.6		10.80		12.0
		55	ASH 27 X 55	16.50		10.6		11.90		13.2
		60	ASH 27 X 60	15.20		11.5		13.00		14.4
		65	ASH 27 X 65	14.00		12.5		14.00		15.6
		70	ASH 27 X 70	13.03		13.4		15.10		16.8
		75	ASH 27 X 75	12.10		14.4		16.20		18.0
		80	ASH 27 X 80	11.40		15.4		17.30		19.2
		90	ASH 27 X 90	10.13		17.3		19.40		21.6
		100	ASH 27 X 100	9.12		19.2		21.60		24.0
		125	ASH 27 X 125	7.30		24.0		27.00		30.0
150	ASH 27 X 150	6.08	28.8	32.40	36.0					
175	ASH 27 X 175	5.21	33.6	37.80	42.0					

JIS



JIS B 5012 SERIES



H	R	Lo	Part No.	P/f	L ₁ 19%		L ₂ 22%		L ₃ 24%		
					N	D	N	D	N	D	
30	15	25	ASH 30 X 25	45.00	2,120	4.8	2,380	5.4	2,550	6.0	
		30	ASH 30 X 30	37.50		5.8					7.2
		35	ASH 30 X 35	32.26		6.7					8.4
		40	ASH 30 X 40	28.12		7.7					9.6
		45	ASH 30 X 45	25.00		8.6					10.6
		50	ASH 30 X 50	22.50		9.6					12.0
		55	ASH 30 X 55	20.40		10.6					13.2
		60	ASH 30 X 60	18.75		11.5					14.4
		65	ASH 30 X 65	17.30		12.5					15.6
		70	ASH 30 X 70	16.07		13.4					16.8
		75	ASH 30 X 75	15.00		14.4					18.0
		80	ASH 30 X 80	14.06		15.4					19.2
		90	ASH 30 X 90	12.50		17.3					21.6
		100	ASH 30 X 100	11.25		19.2					24.0
		35	17.5	40		ASH 35 X 40					38.22
45	ASH 35 X 45			33.98	8.6	10.6					
50	ASH 35 X 50			30.58	9.6	12.0					
55	ASH 35 X 55			27.80	10.6	13.2					
60	ASH 35 X 60			25.48	11.5	14.4					
65	ASH 35 X 65			23.53	12.5	15.6					
70	ASH 35 X 70			21.84	13.4	16.8					
75	ASH 35 X 75			20.39	14.4	18.0					
80	ASH 35 X 80			19.11	15.4	19.2					
90	ASH 35 X 90			16.99	17.3	21.6					
40	20	40	ASH 40 X 40	50.00	3,770	7.7	4,240	9.6	4,710	9.6	
		50	ASH 40 X 50	40.00		9.6					12.0
		60	ASH 40 X 60	33.33		11.5					14.4
		70	ASH 40 X 70	28.57		13.4					16.8
		80	ASH 40 X 80	25.00		15.4					18.0
		90	ASH 40 X 90	22.22		17.3					19.2
		100	ASH 40 X 100	20.00		19.2					21.6
		125	ASH 40 X 125	16.00		24.0					24.0
		150	ASH 40 X 150	13.33		28.8					30.0
		175	ASH 40 X 175	11.42		33.6					36.0
200	ASH 40 X 200	10.00	38.4	42.0							
250	ASH 40 X 250	8.00	48.0	60.0							

JIS



JIS B 5012 SERIES



HEAVY DUTY JIS COLOUR CODED **GREEN**

CHARGE FORTE JIS COULEUR **VERTE**

CARGA FUERTE **VERDE** CÓDIGO COLOR SEGÚN JIS

SCHWERE BEANSPRUCHUNG JIS FARBUNTERLEGTES **GRÜN**

CARICO PESANTE CODICE CROMATICO JIS **VERDE**

CARGA PESADA COR DA SÉRIE JIS **VERDE**

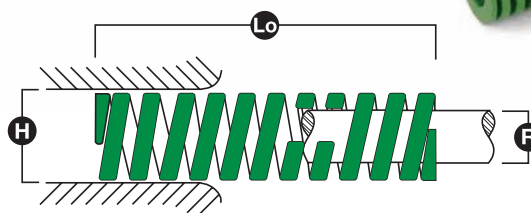

H	R	Lo	Part No.	P/f	L ₁ 19%		L ₂ 22%		L ₃ 24%	
					N	D	N	D	N	D
50	25	50	ASH 50 X 50	62.50	5,880	9.6	6,620	10.8	7,360	12.0
		60	ASH 50 X 60	52.08		11.5		13.0		14.4
		70	ASH 50 X 70	44.64		13.4		15.1		16.8
		80	ASH 50 X 80	39.06		15.4		17.3		19.2
		90	ASH 50 X 90	34.72		17.3		19.4		21.6
		100	ASH 50 X 100	31.25		19.2		21.6		24.0
		125	ASH 50 X 125	25.00		24.0		27.0		30.0
		150	ASH 50 X 150	20.83		28.8		32.4		36.0
		175	ASH 50 X 175	17.85		33.6		37.8		42.0
		200	ASH 50 X 200	15.62		38.4		43.2		48.0
		250	ASH 50 X 250	12.50		48.0		54.0		60.0
300	ASH 50 X 300	10.41	57.6	64.8	72.0					
60	30	60	ASH 60 X 60	75.00	8,470	11.5	9,540	13.0	10,590	14.4
		70	ASH 60 X 70	64.28		13.4		15.1		16.8
		80	ASH 60 X 80	56.25		15.4		17.3		19.2
		90	ASH 60 X 90	50.00		17.3		19.4		21.6
		100	ASH 60 X 100	45.00		19.2		21.6		24.0
		125	ASH 60 X 125	36.00		24.0		27.0		30.0
		150	ASH 60 X 150	30.00		28.8		32.4		36.0
		175	ASH 60 X 175	25.71		33.6		37.8		42.0
		200	ASH 60 X 200	22.50		38.4		43.2		48.0
		250	ASH 60 X 250	18.00		48.0		54.0		60.0
		300	ASH 60 X 300	15.00		57.6		64.8		72.0

JIS B 5012 SERIES



EXTRA HEAVY DUTY JIS COLOUR CODED **BROWN**

CHARGE EXTRA FORTE JIS COULEUR **MARRON**

CARGA EXTRA FUERTE **MARRON** CÓDIGO COLOR SEGÚN JIS

EXTRA STARKE BEANSPRUCHUNG JIS FARBUNTERLEGTES **BRAUN**

CARICO EXTRA PESANTE CODICE CROMATICO JIS **MARRONE**

CARGA EXTRA PESADA COR DA SÉRIE JIS **MARRON**

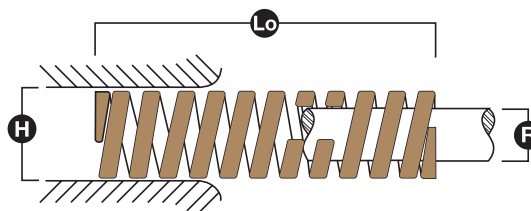

H	R	Lo	Part No.	P/f	L ₁ 16%		L ₂ 18%		L ₃ 20%	
					N	D	N	D	N	D
8	4	10	ASB 8 X 10	16.94	255	1.6	299	1.8	343	2.0
		15	ASB 8 X 15	11.30		2.4		2.7		3.0
		20	ASB 8 X 20	8.47		3.2		3.6		4.0
		25	ASB 8 X 25	6.78		4.0		4.5		5.0
		30	ASB 8 X 30	5.65		4.8		5.4		6.0
		35	ASB 8 X 35	4.84		5.6		6.3		7.0
		40	ASB 8 X 40	4.20		6.4		7.2		8.0
		45	ASB 8 X 45	3.77		7.2		8.1		9.0
		50	ASB 8 X 50	3.39		8.0		9.0		10.0
		55	ASB 8 X 55	3.08		8.8		9.9		11.0
		60	ASB 8 X 60	2.82	9.6	10.8	12.0			
10	5	20	ASB 10 X 20	11.25	353	3.2	402	3.6	441	4.0
		25	ASB 10 X 25	9.00		4.0		4.5		5.0
		30	ASB 10 X 30	7.50		4.8		5.4		6.0
		35	ASB 10 X 35	6.43		5.6		6.3		7.0
		40	ASB 10 X 40	5.63		6.4		7.2		8.0
		45	ASB 10 X 45	5.00		7.2		8.1		9.0
		50	ASB 10 X 50	4.50		8.0		9.0		10.0
		55	ASB 10 X 55	4.09		8.8		9.9		11.0
		60	ASB 10 X 60	3.75		9.6		10.8		12.0
		65	ASB 10 X 65	3.47		10.4		11.7		13.0
		70	ASB 10 X 70	3.21	11.2	12.6	14.0			
		75	ASB 10 X 75	3.00	12.0	13.5	15.0			
		80	ASB 10 X 80	2.82	12.8	14.4	16.0			
12	6	20	ASB 12 X 20	14.50	451	3.2	510	3.6	569	4.0
		25	ASB 12 X 25	11.60		4.0		4.5		5.0
		30	ASB 12 X 30	9.67		4.8		5.4		6.0
		35	ASB 12 X 35	8.29		5.6		6.3		7.0
		40	ASB 12 X 40	7.25		6.4		7.2		8.0
		45	ASB 12 X 45	6.44		7.2		8.1		9.0
		50	ASB 12 X 50	5.80		8.0		9.0		10.0
		55	ASB 12 X 55	5.27		8.8		9.9		11.0
		60	ASB 12 X 60	4.83		9.6		10.8		12.0
		65	ASB 12 X 65	4.44		10.4		11.7		13.0
		70	ASB 12 X 70	4.13	11.2	12.6	14.0			
		75	ASB 12 X 75	3.85	12.0	13.5	15.0			
		80	ASB 12 X 80	3.61	12.8	14.4	16.0			
14	7	25	ASB 14 X 25	15.00	588	4.0	667	4.5	736	5.0
		30	ASB 14 X 30	12.50		4.8		5.4		6.0
		35	ASB 14 X 35	10.72		5.6		6.3		7.0
		40	ASB 14 X 40	9.38		6.4		7.2		8.0
		45	ASB 14 X 45	8.34		7.2		8.1		9.0
		50	ASB 14 X 50	7.50		8.0		9.0		10.0
		55	ASB 14 X 55	6.82		8.8		9.9		11.0
		60	ASB 14 X 60	6.25		9.6		10.8		12.0
		65	ASB 14 X 65	5.77		10.4		11.7		13.0
		70	ASB 14 X 70	5.36		11.2		12.6		14.0
		75	ASB 14 X 75	5.00	12.0	13.5	15.0			
		80	ASB 14 X 80	4.69	12.8	14.4	16.0			
		90	ASB 14 X 90	4.17	14.4	16.2	18.0			

JIS



JIS B 5012 SERIES



EXTRA HEAVY DUTY JIS COLOUR CODED **BROWN**

CHARGE EXTRA FORTE JIS COULEUR **MARRON**

CARGA EXTRA FUERTE **MARRON** CÓDIGO COLOR SEGÚN JIS

EXTRA STARKE BEANSPRUCHUNG JIS FARBUNTERLEGTES **BRAUN**

CARICO EXTRA PESANTE CODICE CROMATICO JIS **MARRONE**

CARGA EXTRA PESADA COR DA SÉRIE JIS **MARRON**

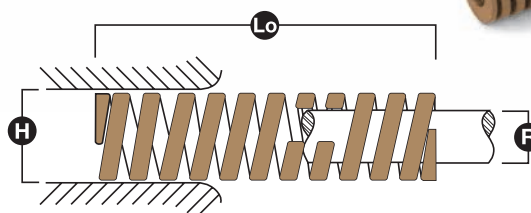

H	R	Lo	Part No.	P/f	L ₁ 16%		L ₂ 18%		L ₃ 20%		
					N	D	N	D	N	D	
16	8	25	ASB 16 X 25	20.00	785	4.0	883	981	5.0		
		30	ASB 16 X 30	16.67		4.8				5.4	6.0
		35	ASB 16 X 35	14.29		5.6				6.3	7.0
		40	ASB 16 X 40	12.50		6.4				7.2	8.0
		45	ASB 16 X 45	11.11		7.2				8.1	9.0
		50	ASB 16 X 50	10.00		8.0				9.0	10.0
		55	ASB 16 X 55	9.09		8.8				9.9	11.0
		60	ASB 16 X 60	8.34		9.6				10.8	12.0
		65	ASB 16 X 65	7.69		10.4				11.7	13.0
		70	ASB 16 X 70	7.14		11.2				12.6	14.0
		75	ASB 16 X 75	6.67		12.0				13.5	15.0
		80	ASB 16 X 80	6.25		12.8				14.4	16.0
90	ASB 16 X 90	5.56	14.4	16.2	18.0						
100	ASB 16 X 100	5.00	16.0	18.0	20.0						
18	9	25	ASB 18 X 25	25.00	981	4.0	1,108	1,226	5.0		
		30	ASB 18 X 30	20.84		4.8				5.4	6.0
		35	ASB 18 X 35	17.86		5.6				6.3	7.0
		40	ASB 18 X 40	15.63		6.4				7.2	8.0
		45	ASB 18 X 45	13.89		7.2				8.1	9.0
		50	ASB 18 X 50	12.50		8.0				9.0	10.0
		55	ASB 18 X 55	11.37		8.8				9.9	11.0
		60	ASB 18 X 60	10.42		9.6				10.8	12.0
		65	ASB 18 X 65	9.62		10.4				11.7	13.0
		70	ASB 18 X 70	8.93		11.2				12.6	14.0
		75	ASB 18 X 75	8.34		12.0				13.5	15.0
		80	ASB 18 X 80	7.82		12.8				14.4	16.0
90	ASB 18 X 90	6.95	14.4	16.2	18.0						
100	ASB 18 X 100	6.26	16.0	18.0	20.0						
20	10	25	ASB 20 X 25	32.00	1,255	4.0	1,412	1,569	5.0		
		30	ASB 20 X 30	26.67		4.8				5.4	6.0
		35	ASB 20 X 35	22.86		5.6				6.3	7.0
		40	ASB 20 X 40	20.00		6.4				7.2	8.0
		45	ASB 20 X 45	17.78		7.2				8.1	9.0
		50	ASB 20 X 50	16.00		8.0				9.0	10.0
		55	ASB 20 X 55	14.55		8.8				9.9	11.0
		60	ASB 20 X 60	13.33		9.6				10.8	12.0
		65	ASB 20 X 65	12.31		10.4				11.7	13.0
		70	ASB 20 X 70	11.43		11.2				12.6	14.0
		75	ASB 20 X 75	10.67		12.0				13.5	15.0
		80	ASB 20 X 80	10.00		12.8				14.4	16.0
		90	ASB 20 X 90	8.89		14.4				16.2	18.0
		100	ASB 20 X 100	8.00		16.0				18.0	20.0
		125	ASB 20 X 125	6.40		20.0				22.5	25.0
150	ASB 20 X 150	5.33	24.0	27.0	30.0						

JIS

JIS B 5012 SERIES

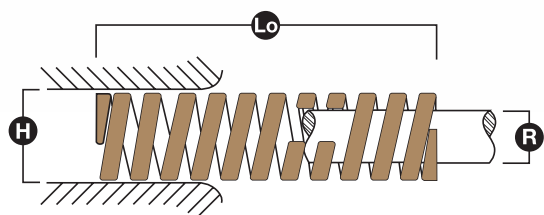

H	R	Lo	Part No.	P/f	L ₁ 16%		L ₂ 18%		L ₃ 20%	
					N	D	N	D	N	D
22	11	25	ASB 22 X 25	39.00	1,530	4.0	1,726	4.5	1,912	5.0
		30	ASB 22 X 30	32.50		4.8		5.4		6.0
		35	ASB 22 X 35	27.86		5.6		6.3		7.0
		40	ASB 22 X 40	24.38		6.4		7.2		8.0
		45	ASB 22 X 45	21.67		7.2		8.1		9.0
		50	ASB 22 X 50	19.50		8.0		9.0		10.0
		55	ASB 22 X 55	17.73		8.8		9.9		11.0
		60	ASB 22 X 60	16.25		9.6		10.8		12.0
		65	ASB 22 X 65	15.00		10.4		11.7		13.0
		70	ASB 22 X 70	13.93		11.2		12.6		14.0
		75	ASB 22 X 75	13.00		12.0		13.5		15.0
		80	ASB 22 X 80	12.19		12.8		14.4		16.0
		90	ASB 22 X 90	10.83		14.4		16.2		18.0
		100	ASB 22 X 100	9.75		16.0		18.0		20.0
		125	ASB 22 X 125	7.80		20.0		22.5		25.0
150	ASB 22 X 150	6.50	24.0	27.0	30.0					
25	12.5	25	ASB 25 X 25	49.00	1,922	4.0	2,170	4.5	2,400	5.0
		30	ASB 25 X 30	40.80		4.8		5.4		6.0
		35	ASB 25 X 35	35.00		5.6		6.3		7.0
		40	ASB 25 X 40	30.60		6.4		7.2		8.0
		45	ASB 25 X 45	27.20		7.2		8.1		9.0
		50	ASB 25 X 50	24.50		8.0		9.0		10.0
		55	ASB 25 X 55	22.30		8.8		9.9		11.0
		60	ASB 25 X 60	20.40		9.6		10.8		12.0
		65	ASB 25 X 65	18.80		10.4		11.7		13.0
		70	ASB 25 X 70	17.50		11.2		12.6		14.0
		75	ASB 25 X 75	16.30		12.0		13.5		15.0
		80	ASB 25 X 80	15.30		12.8		14.4		16.0
		90	ASB 25 X 90	13.60		14.4		16.2		18.0
		100	ASB 25 X 100	12.30		16.0		18.0		20.0
		125	ASB 25 X 125	9.80		20.0		22.5		25.0
150	ASB 25 X 150	8.17	24.0	27.0	30.0					
175	ASB 25 X 175	7.00	28.0	31.5	35.0					
27	13.5	25	ASB 27 X 25	58.00	2,280	4.0	2,560	4.5	2,840	5.0
		30	ASB 27 X 30	48.33		4.8		5.4		6.0
		35	ASB 27 X 35	41.43		5.6		6.3		7.0
		40	ASB 27 X 40	36.25		6.4		7.2		8.0
		45	ASB 27 X 45	32.22		7.2		8.1		9.0
		50	ASB 27 X 50	29.00		8.0		9.0		10.0
		55	ASB 27 X 55	26.36		8.8		9.9		11.0
		60	ASB 27 X 60	24.17		9.6		10.8		12.0
		65	ASB 27 X 65	22.31		10.4		11.7		13.0
		70	ASB 27 X 70	20.71		11.2		12.6		14.0
		75	ASB 27 X 75	19.33		12.0		13.5		15.0
		80	ASB 27 X 80	18.13		12.8		14.4		16.0
		90	ASB 27 X 90	16.11		14.4		16.2		18.0
		100	ASB 27 X 100	14.50		16.0		18.0		20.0
		125	ASB 27 X 125	11.60		20.0		22.5		25.0
150	ASB 27 X 150	9.67	24.0	27.0	30.0					
175	ASB 27 X 175	8.28	28.0	31.5	35.0					

JIS



JIS B 5012 SERIES



EXTRA HEAVY DUTY JIS COLOUR CODED **BROWN**

CHARGE EXTRA FORTE JIS COULEUR **MARRON**

CARGA EXTRA FUERTE **MARRON** CÓDIGO COLOR SEGÚN JIS

EXTRA STARKE BEANSPRUCHUNG JIS FARBUNTERLEGTES **BRAUN**

CARICO EXTRA PESANTE CODICE CROMATICO JIS **MARRONE**

CARGA EXTRA PESADA COR DA SÉRIE JIS **MARRON**

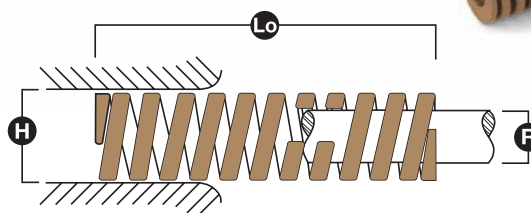

H	R	Lo	Part No.	P/f	L ₁ 16%		L ₂ 18%		L ₃ 20%		
					N	D	N	D	N	D	
30	15	25	ASB 30 X 25	72.00	2,820	4.0	3,180	4.5	3,530	5.0	
		30	ASB 30 X 30	60.00		4.8				5.4	6.0
		35	ASB 30 X 35	51.43		5.6				6.3	7.0
		40	ASB 30 X 40	45.00		6.4				7.2	8.0
		45	ASB 30 X 45	40.00		7.2				8.1	9.0
		50	ASB 30 X 50	36.00		8.0				9.0	10.0
		55	ASB 30 X 55	32.72		8.8				9.9	11.0
		60	ASB 30 X 60	30.00		9.6				10.8	12.0
		65	ASB 30 X 65	27.69		10.4				11.7	13.0
		70	ASB 30 X 70	25.71		11.2				12.6	14.0
		75	ASB 30 X 75	24.00		12.0				13.5	15.0
		80	ASB 30 X 80	22.50		12.8				14.4	16.0
		90	ASB 30 X 90	20.00		14.4				16.2	18.0
		100	ASB 30 X 100	18.00		16.0				18.0	20.0
		125	ASB 30 X 125	14.40		20.0				22.5	25.0
150	ASB 30 X 150	12.00	24.0	27.0	30.0						
175	ASB 30 X 175	10.28	28.0	31.5	35.0						
200	ASB 30 X 200	9.00	32.0	36.0	40.0						
35	17.5	40	ASB 35 X 40	61.20	3,840	6.4	4,320	7.2	4,810	8.0	
		45	ASB 35 X 45	54.44		7.2				8.1	9.0
		50	ASB 35 X 50	49.00		8.0				9.0	10.0
		55	ASB 35 X 55	44.54		8.8				9.9	11.0
		60	ASB 35 X 60	40.83		9.6				10.8	12.0
		65	ASB 35 X 65	37.69		10.4				11.7	13.0
		70	ASB 35 X 70	35.00		11.2				12.6	14.0
		75	ASB 35 X 75	32.67		12.0				13.5	15.0
		80	ASB 35 X 80	30.62		12.8				14.4	16.0
		90	ASB 35 X 90	27.22		14.4				16.2	18.0
		100	ASB 35 X 100	24.50		16.0				18.0	20.0
		125	ASB 35 X 125	19.60		20.0				22.5	25.0
150	ASB 35 X 150	16.33	24.0	27.0	30.0						
175	ASB 35 X 175	14.00	28.0	31.5	35.0						
200	ASB 35 X 200	12.25	32.0	36.0	40.0						
40	20	40	ASB 40 X 40	80.00	5,020	6.4	5,650	7.2	6,280	8.0	
		50	ASB 40 X 50	64.00		8.0				9.0	10.0
		60	ASB 40 X 60	53.33		9.6				10.8	12.0
		70	ASB 40 X 70	45.71		11.2				12.6	14.0
		80	ASB 40 X 80	40.00		12.8				14.4	16.0
		90	ASB 40 X 90	35.55		14.4				16.2	18.0
		100	ASB 40 X 100	32.00		16.0				18.0	20.0
		125	ASB 40 X 125	25.60		20.0				22.5	25.0
		150	ASB 40 X 150	21.33		24.0				27.0	30.0
		175	ASB 40 X 175	18.28		28.0				31.5	35.0
		200	ASB 40 X 200	15.00		32.0				36.0	40.0
		250	ASB 40 X 250	12.80		40.0				45.0	50.0

JIS



JIS B 5012 SERIES

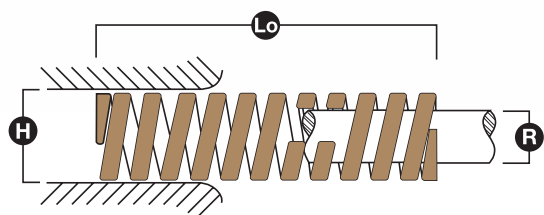

H	R	Lo	Part No.	P/f	L ₁ 16%		L ₂ 18%		L ₃ 20%	
					N	D	N	D	N	D
50	25	50	ASB 50 X 50	100.00	7,850	8.0	8,830	9.0	9,810	10.0
		60	ASB 50 X 60	83.33		9.6		10.8		12.0
		70	ASB 50 X 70	71.42		11.2		12.6		14.0
		80	ASB 50 X 80	62.50		12.8		14.4		16.0
		90	ASB 50 X 90	55.55		14.4		16.2		18.0
		100	ASB 50 X 100	50.00		16.0		18.0		20.0
		125	ASB 50 X 125	40.00		20.0		22.5		25.0
		150	ASB 50 X 150	33.33		24.0		27.0		30.0
		175	ASB 50 X 175	27.57		28.0		31.5		35.0
		200	ASB 50 X 200	25.00		32.0		36.0		40.0
		250	ASB 50 X 250	20.00		40.0		45.0		50.0
300	ASB 50 X 300	16.66	48.0	54.0	60.0					
60	30	60	ASB 60 X 60	120.00	11,300	9.6	12,710	10.8	14,122	12.0
		70	ASB 60 X 70	102.00		11.2		12.6		14.0
		80	ASB 60 X 80	90.00		12.8		14.4		16.0
		90	ASB 60 X 90	80.00		14.4		16.2		18.0
		100	ASB 60 X 100	72.00		16.0		18.0		20.0
		125	ASB 60 X 125	57.60		20.0		22.5		25.0
		150	ASB 60 X 150	48.00		24.0		27.0		30.0
		175	ASB 60 X 175	41.14		28.0		31.5		35.0
		200	ASB 60 X 200	36.00		32.0		36.0		40.0
		250	ASB 60 X 250	28.80		40.0		45.0		50.0
		300	ASB 60 X 300	24.00		48.0		54.0		60.0

COMPRESSION SPRING ASSORTMENT KITS

ASSORTIMENTS DE RESSORTS DE COMPRESSION

SURTIDO DE MUELLES DE COMPRESION

DRUCKFEDER SORTIMENT SET

KIT ASSORTITO DI MOLLE A COMPRESIONE

CONJUNTO DE VARIEDADES DE MOLA DE COMPRESSÃO

Part No.	H	d	P/f	Sh	Lo	Unit Pack
107-011	2.36	0.36	0.09	101	250	12
107-020	3.18	0.30	0.02	76	250	12
107-021	3.18	0.41	0.07	102	250	12
107-030	4.78	0.36	0.01	50	250	12
107-031	4.78	0.46	0.05	64	250	12
107-032	4.78	0.66	0.24	86	250	12
107-033	4.78	0.89	0.67	169	250	12
107-040	6.35	0.46	0.02	43	250	12
107-042	6.35	0.66	0.12	63	250	12
107-043	6.35	0.79	0.26	79	250	12
107-044	6.35	0.89	0.32	116	250	12
107-045	6.35	1.04	1.02	94	250	12
107-046	6.35	1.19	1.64	119	250	12
107-050	7.92	0.56	0.03	56	250	12
107-051	7.92	0.79	0.11	87	250	12
107-052	7.92	0.94	0.24	103	250	12
107-053	7.92	1.04	0.50	83	250	12
107-054	7.92	1.19	1.06	90	250	12
107-055	7.92	1.40	2.00	112	250	12
107-060	9.53	0.79	0.06	87	250	12
107-061	9.53	0.89	0.11	89	250	12
107-062	9.53	1.09	0.38	76	250	12
107-063	9.53	1.19	0.47	102	250	12
107-064	9.53	1.40	1.23	84	250	12
107-065	9.53	1.57	2.16	102	250	12
107-066	9.53	1.91	4.86	133	250	12
107-070	11.13	0.89	0.09	62	250	12
107-071	11.13	1.19	0.33	84	250	12
107-072	11.13	1.40	0.79	84	250	12
107-073	11.13	1.57	1.21	102	250	12
107-074	11.13	1.91	3.47	105	250	12
107-075	11.13	2.16	5.45	130	250	12
107-080	12.70	0.89	0.04	80	250	12
107-081	12.70	1.19	0.19	90	250	12
107-082	12.70	1.40	0.41	98	250	12
107-083	12.70	1.57	1.24	61	250	12
107-084	12.70	1.91	2.63	86	250	12
107-085	12.70	2.31	5.69	116	250	12
107-509-000	12.70	1.04	0.11	84	450	12
107-509-100	12.70	1.37	0.41	99	450	12
107-509-200	14.27	1.57	0.33	163	450	12
107-509-300	14.27	1.83	0.93	132	450	12
107-510-000	15.88	1.37	0.25	74	450	12
107-510-100	17.48	1.57	0.33	85	450	12
107-510-200	17.48	1.83	0.55	107	450	12
107-510-300	17.48	1.73	0.40	109	450	12
107-511-000	20.62	1.57	0.22	71	450	12
107-511-100	20.62	2.03	0.67	91	450	12
107-511-200	22.23	2.49	1.39	101	450	12
107-511-300	23.83	3.18	2.54	157	450	12
107-512-100	23.83	2.03	0.41	90	450	12
107-512-200	25.40	2.49	1.00	87	450	6
107-514-100	34.93	3.76	2.25	113	450	6

Part No.	Do	d	P/f	Sh	Lo	Unit Pack
020-076	2.77	0.46	2.10	9	21	12
020-084	4.78	0.30	0.06	6	24	12
020-060	12.70	1.83	9.10	15	25	12
020-059	13.49	2.67	76.30	24	26	12
020-080	7.14	1.02	3.15	16	32	12
020-079	7.14	1.02	3.68	14	33	12
020-081	7.92	0.56	0.11	13	50	12
020-065	22.23	3.05	19.25	24	51	12
020-088	9.53	1.22	1.93	25	52	12
020-063	23.83	2.03	2.80	16	52	12
020-092	12.70	1.22	0.98	23	52	12
020-069	14.99	1.02	0.62	10	56	12
020-091	12.70	1.60	3.15	25	64	12
020-071	11.13	1.04	0.46	28	65	12
020-062	25.78	3.05	9.80	29	65	12
020-066	21.82	3.43	26.95	38	66	12
020-089	11.13	1.22	1.26	24	67	12
020-072	19.05	2.69	13.13	30	67	12
020-068	15.88	2.03	5.25	27	72	12
020-064	22.23	2.34	3.76	28	78	12
020-067	17.48	2.67	10.15	50	102	12
020-056	4.47	0.36	0.03	57	254	12
020-055	6.35	0.56	0.05	63	254	12
020-052	9.53	1.19	0.47	108	292	12
020-053	9.12	1.22	0.39	134	305	12
020-051	13.11	1.60	0.49	138	305	12

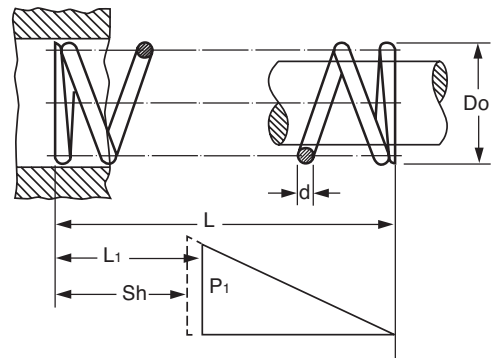
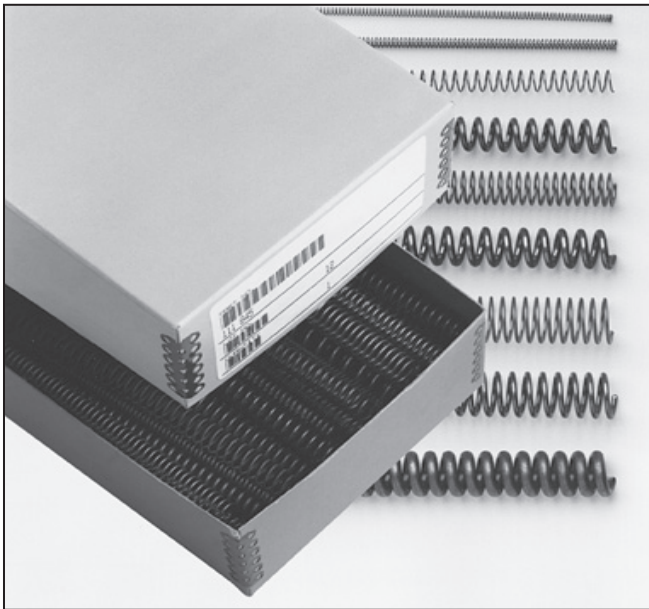

EXTENSION SPRING ASSORTMENTS

ASSORTIMENTS DE RESSORTS DE TRACTION

SURTIDO DE MUELLES DE EXTENSION

ERWEITERUNGSSORTIMENT

ASSORTIMENTO DI MOLLE DI TRAZIONE

VARIETADES DE MOLAS DE EXTENSAO

Part No.	Do	d	P/f	Lo	N @ L ₁	Unit Pack
020-042	4.78	0.36	0.03	25	0.89 @ 38.10	12
020-040	5.94	0.51	0.13	29	2.67 @ 41.40	12
020-037	8.74	1.22	2.63	37	44.48 @ 45.97	12
020-034	12.70	2.03	13.11	41	102.30 @ 47.75	12
020-095	18.24	2.72	15.90	51	226.85 @ 63.50	12
020-032	19.05	2.67	8.05	66	131.22 @ 75.44	12
020-033	19.05	2.03	1.80	67	55.60 @ 92.96	12
020-019	9.53	1.04	0.33	83	23.13 @ 133.35	12
020-020	6.35	0.71	0.14	102	8.45 @ 152.40	12
020-024	18.26	2.67	5.39	102	162.35 @ 127.00	12
020-023	18.64	1.60	0.30	103	19.13 @ 153.16	12
020-022	12.29	1.60	0.92	114	62.27 @ 165.10	12
020-026	7.92	1.04	0.33	127	13.79 @ 165.10	12
020-028	11.13	1.60	1.14	133	71.17 @ 184.15	12
020-025	13.49	1.57	0.88	133	37.81 @ 158.75	12
020-018	6.35	1.04	0.75	136	35.58 @ 148.34	12
020-027	8.74	1.22	0.46	137	27.58 @ 187.45	12
020-014	9.53	1.37	0.70	140	44.48 @ 190.50	12
020-013	13.51	2.03	1.84	140	108.98 @ 177.80	12
020-012	13.89	2.03	1.75	143	106.75 @ 193.80	12
020-017	6.35	0.71	0.10	146	7.12 @ 196.85	12
020-015	7.54	1.22	0.77	146	41.37 @ 196.85	12
020-029	22.23	3.05	3.24	152	117.87 @ 177.80	6
020-016	6.76	0.89	0.19	156	17.79 @ 206.50	12
020-009	11.13	1.22	0.19	164	18.68 @ 214.38	12
020-010	8.33	0.89	0.10	165	9.79 @ 215.90	12
020-030	26.97	3.43	2.36	203	169.02 @ 254.00	6
020-031	25.40	2.67	0.69	216	74.73 @ 260.35	3
020-005	9.12	1.37	0.40	254	27.58 @ 330.20	12
020-004	12.70	1.57	0.37	254	45.37 @ 304.80	12
020-003	15.88	1.83	0.37	254	39.14 @ 330.20	6
020-002	20.62	1.83	0.13	254	24.91 @ 304.80	3
020-001	22.23	2.34	0.44	254	51.15 @ 330.20	3
020-099	16.93	2.67	5.74	98	177.92 @ 127.00	6
020-029	22.23	3.05	3.24	152	117.87 @ 177.80	6
020-030	25.40	3.43	2.36	203	169.02 @ 254.00	6
020-100	28.58	3.76	2.45	254	213.50 @ 330.20	6
020-101	31.75	4.11	2.21	305	293.57 @ 381.00	6
020-102	34.93	4.50	2.43	356	329.15 @ 457.20	6
020-103	39.91	5.26	2.89	406	444.80 @ 533.40	6

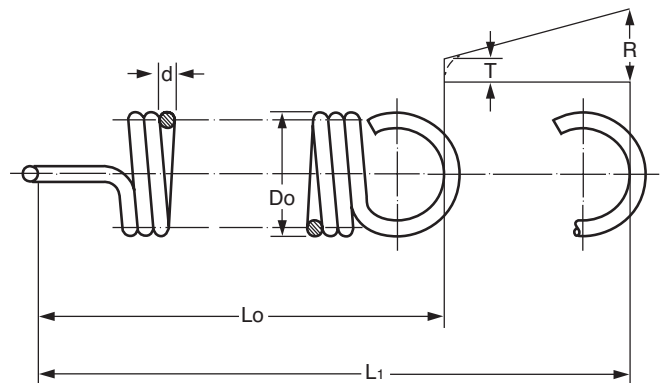
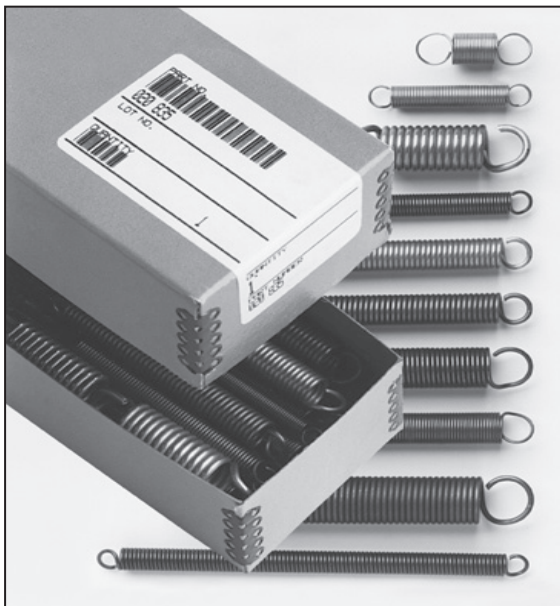



To Convert	From	To	Multiply By
Length	Metres	Inches	39.3701
	Inches	Millimetres	25.4
	Millimetres	Inches	0.0393
Rate	Kg/mm	lb/in	55.998
		N/mm	9.807
		kN/m	9.807
	lb/in	kg/mm	0.017858
		N/mm or kN/m	0.17519
	kN/m or N/mm	kg/mm	0.101968
	lb/in	5.7099	
Force	Newtons	Kilograms	0.102
		Pounds	0.22467
		Grams	102
	Kilograms	Newtons	9.807
		Pounds	2.2046
		Grams	1000
	Pounds	Newtons	4.448
		Kilograms	0.4536
		Grams	453.6
	Grams	Newtons	0.009807
		Kilograms	0.001
		Pounds	0.0022046
Torque	kg – mm	lb – ins	0.086796
		N – mm	0.009807
	lb – ins	kg – mm	11.52125
		N – mm	0.1129889
	N – mm	kg – mm	101.968
		lb – ins	8.85041



Pour convertir	De	En	Multiplier par
Longueur	Mètres	Inches	39.3701
	Inches	Millimètres	25.4
	Millimètres	Inches	0.0393
Raideur	Kg/mm	lb/in	55.998
		N/mm	9.807
		kN/m	9.807
	lb/in	kg/mm	0.017858
		N/mm or kN/m	0.17519
	kN/m or N/mm	kg/mm	0.101968
	lb/in	5.7099	
Charge	Newtons	Kilogrammes	0.102
		Livres	0.22467
		Grammes	102
	Kilogrammes	Newtons	9.807
		Livres	2.2046
		Grammes	1000
	Livres	Newtons	4.448
		Kilogrammes	0.4536
		Grammes	453.6
	Grammes	Newtons	0.009807
		Kilogrammes	0.001
		Livres	0.0022046
Couple	kg – mm	lb – ins	0.086796
		N – mm	0.009807
	lb – ins	kg – mm	11.52125
		N – mm	0.1129889
	N – mm	kg – mm	101.968
		lb – ins	8.85041



Para convertir	De	En	Multiplicado
Longitud	Metros	Pulgadas	39.3701
	Pulgadas	Milímetro	25.4
	Millímetros	Millímetros	0.0393
Cadencia	Kg/mm	lb/in	55.998
		N/mm	9.807
		kN/m	9.807
	lb/in	kg/mm	0.017858
		N/mm or kN/m	0.17519
	kN/m or N/mm	kg/mm	0.101968
	lb/in	5.7099	
Fuerza	Newtones	Kilogramos	0.102
		Libras	0.22467
		Gramos	102
	Kilogramos	Newtones	9.807
		Libras	2.2046
		Gramos	1000
	Libras	Newtones	4.448
		Kilogramos	0.4536
		Gramos	453.6
	Gramos	Newtones	0.009807
		Kilogramos	0.001
		Libras	0.0022046
Par	kg – mm	lb – ins	0.086796
		N – mm	0.009807
	lb – ins	kg – mm	11.52125
		N – mm	0.1129889
	N – mm	kg – mm	101.968
		lb – ins	8.85041



Umrechnung Von	Zu	Multipizieren mit	
Länge	Meter	Inch	39.3701
	Inch	Millimeter	25.4
	Millimeter	Inch	0.0393
Rate	Kg/mm	lb/in	55.998
		N/mm	9.807
		kN/m	9.807
	lb/in	kg/mm	0.017858
		N/mm or kN/m	0.17519
	kN/m or N/mm	kg/mm	0.101968
	lb/in	5.7099	
Kraft	Newton	Kilogramm	0.102
		Pfund	0.22467
		Gramm	102
	Kilogramm	Newton	9.807
		Pfund	2.2046
		Gramm	1000
	Pfund	Newton	4.448
		Kilogramm	0.4536
		Gramm	453.6
	Gramm	Newton	0.009807
		Kilogramm	0.001
		Pfund	0.0022046
Drehmoment	kg – mm	lb – ins	0.086796
		N – mm	0.009807
	lb – ins	kg – mm	11.52125
		N – mm	0.1129889
	N – mm	kg – mm	101.968
		lb – ins	8.85041



Per convertire	da	a	moltiplicare per
Lunghezza	Metri	Pollici	39.3701
	Pollici	Millimetri	25.4
	Millimetri	Pollici	0.0393
Rigidezza	Kg/mm	lb/in	55.998
		N/mm	9.807
		kN/m	9.807
	lb/in	kg/mm	0.017858
		N/mm or kN/m	0.17519
	kN/m or N/mm	kg/mm	0.101968
	lb/in	5.7099	
Forza	Newton	Chilogrammi	0.102
		Libbre	0.22467
		Grammi	102
	Chilogrammi	Newton	9.807
		Libbre	2.2046
		Grammi	1000
	Libbre	Newton	4.448
		Chilogrammi	0.4536
		Grammi	453.6
	Grammi	Newton	0.009807
		Chilogrammi	0.001
		Libbre	0.0022046
Momento di torsione	kg – mm	lb – ins	0.086796
		N – mm	0.009807
	lb – ins	kg – mm	11.52125
		N – mm	0.1129889
	N – mm	kg – mm	101.968
		lb – ins	8.85041



Para Converter	De	Para	Multiplicar por
Comprimento	Metros	Polegadas	39.3701
	Polegadas	Millímetros	25.4
	Millímetros	Polegadas	0.0393
Coefficiente	Kg/mm	Libras/polegadas	55.998
		N/mm	9.807
		kN/m	9.807
	Libras/polegadas.	Kg/mm	0.017858
		N/mm ou kN/m	0.17519
	kN or N/mm	Kg/mm	0.101968
	Libras/polegadas	5.7099	
Força	Newtons	Kilogramas	0.102
		Libras	0.22467
		Gramas	102
	Kilogramas	Newtons	9.807
		Libras	2.2046
		Gramas	1000
	Libras	Newtons	4.448
		Kilogramas	0.4536
		Gramas	453.6
	Gramas	Newtons	0.009807
		Kilogramas	0.001
		Libras	0.0022046
Torque	Kg – mm	Libras-polegadas	0.086796
		N - mm	0.009807
	Libras-polegadas.	Kg – mm	11.52125
		N – mm	0.1129889
	N - mm	Kg – mm	101.968
		Libras- polegadas	85850413



United Kingdom

www.assocspring.co.uk

Associated Spring SPEC

European Headquarters

Unit 4,

Grosvenor Business Centre

Vale Park, Evesham

WR11 1GS

Tel: (44) 1386 443366

Fax: (44) 1386 446669

sales@assocspring.co.uk

France

www.ressortsspec.com

Ressorts SPEC

Bâtiment HERMES 2

ZA de Pissaloup

4 rue Edouard Branly

78190 TRAPPES

Tel: (33) 01 30 68 6363

Fax: (33) 01 30 68 4050

info@ressortsspec.com

Spain

www.bgespana.com

Barnes Group Spain, S.R.L.

La Peña 6 - Pab. 5

01013 Vitoria-Gasteiz

Tel: (34) 945 147542

Fax: (34) 945 137655

ventas@bgespana.com

Mexico

www.asraymond.com

Raymond Distribution -

Mexico SA de CV.

Av. Concordia No 4601-A

Col. Apodaca Centiro

Apodaca,

N.L. Mexico

C.P. 66600

Tel: 52 (81) 81 45 0680

Fax: 52 (81) 81 45 0679

ventas@asraymond.com

Brazil

www.asbg-spec.com.br

Associated Spring Raymond

Rua Wallace Barnes 301A

Distrito Industrial

Caixa Postal 1288

Campinas, SP Brazil

CEP 13054-701

Tel: (55) 193 725 1083

Fax: (55) 193 725 1084

brazil@asbg.com.br

